

REINHOLD ENVIRONMENTAL Ltd.



**2018 APC & Wastewater Round Table
& Expo Presentation**

July 23 & 24, 2018 in Lexington, KY / Hosted by East Kentucky Power Coop

All presentations posted on this website are copyrighted by Reinhold Environmental, Ltd (RE). Any unauthorized downloading, attempts to modify or to incorporate into other presentations, link to other websites, or obtain copies for any other uses than the training of attendees to RE's Conferences is expressly prohibited, unless approved in writing by RE or the original presenter. RE does not assume any liability for the accuracy or contents of any materials contained in this library which were presented and/or created by persons who were not employees of RE.

2018 APC-WASTEWATER CONFERENCE

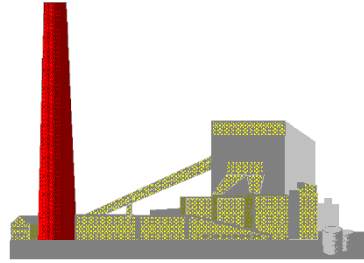

Fundamentals of Troubleshooting an ESP with an Oscilloscope

Presented by Russ Ridgeway

7/22/2018

2018 APC-Wastewater Conference

1



SHEL-B Environmental
Emissions Consulting, Inc.

TEK THS-720 SCOPE FACE

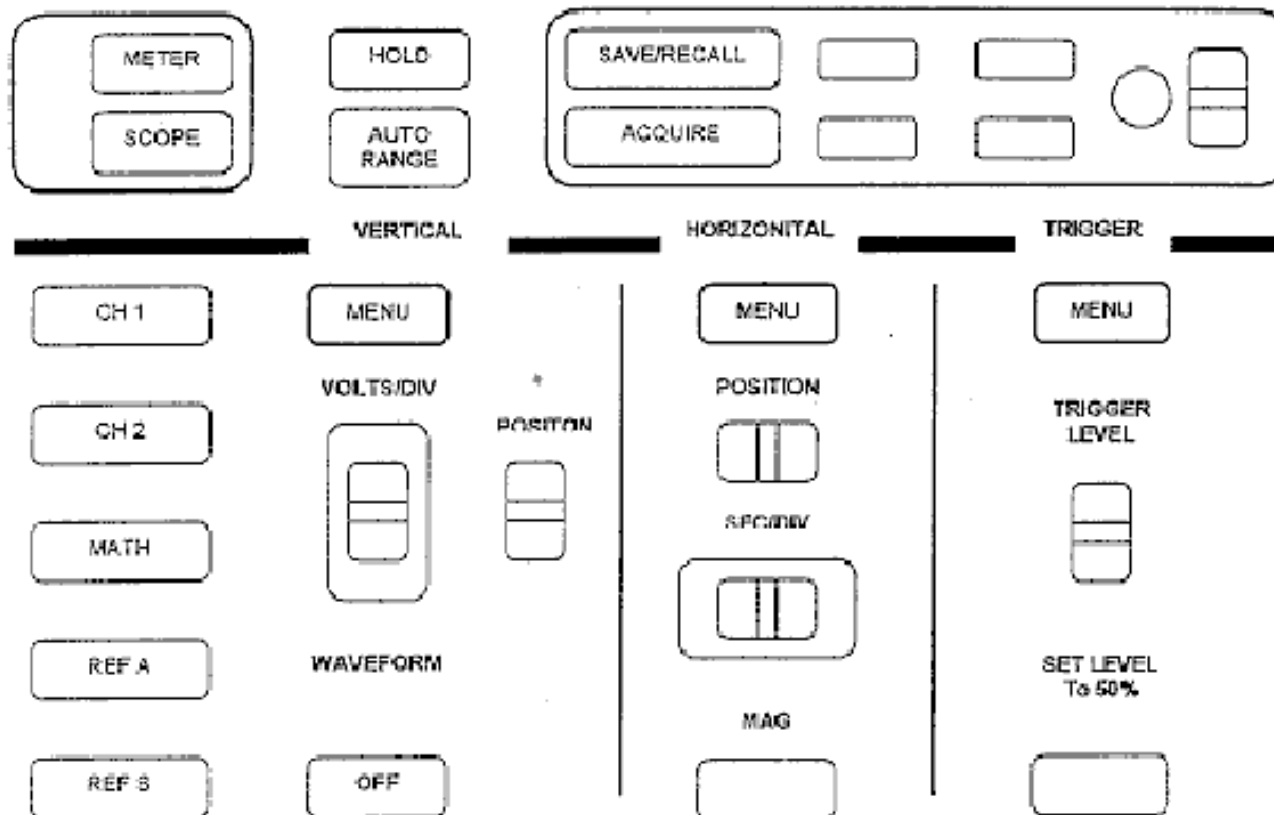

7/22/2018

2018 APC-Wastewater Conference



TEK TPS-2024 SCOPE FACE

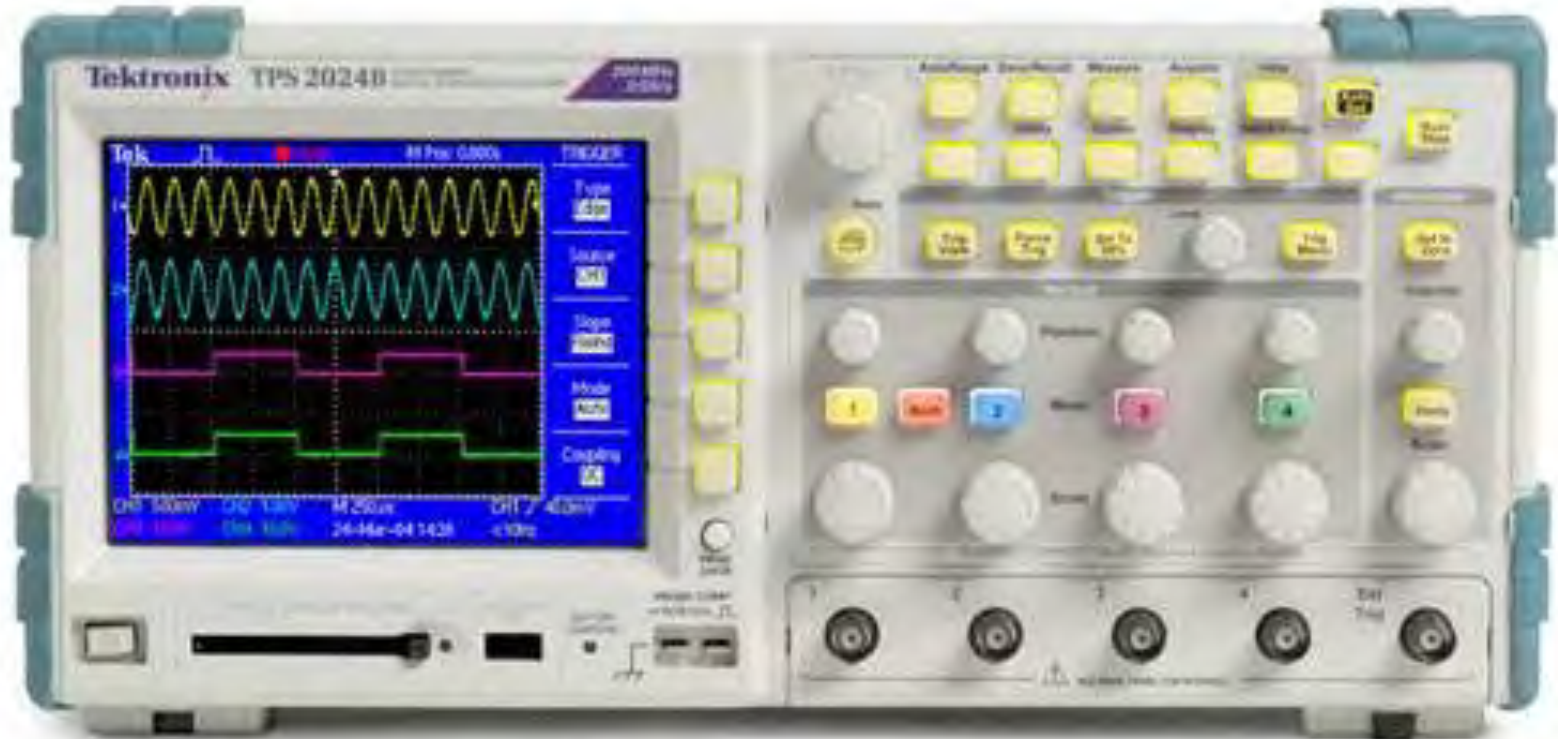

7/22/2018

2018 APC-Wastewater Conference

3



SHEL-B Environmental
Emissions Consulting, Inc.

FLUKE 190 SERIES SCOPE FACE



7/22/2018

2018 APC-Wastewater Conference

4



SHEL-B Environmental
Emissions Consulting, Inc.

AUTOMATIC VOLTAGE CONTROLS

An automatic voltage control (AVC) serves to maintain the voltage level at the optimum value, even when the dust characteristics and concentration exhibit dynamic behavior.

This is achieved by varying the duration that current is applied to the T/R set.



WHERE A CONTROL SHOULD OPERATE

- **TR set rating**
- **Artificial limit (manually or energy management)**
- **Spark limited**
- **SCR limited (full conduction of the SCRs)**

7/22/2018

2018 APC-Wastewater Conference

6



SHEL-B Environmental
Emissions Consulting, Inc.

TYPICAL AVC CIRCUIT

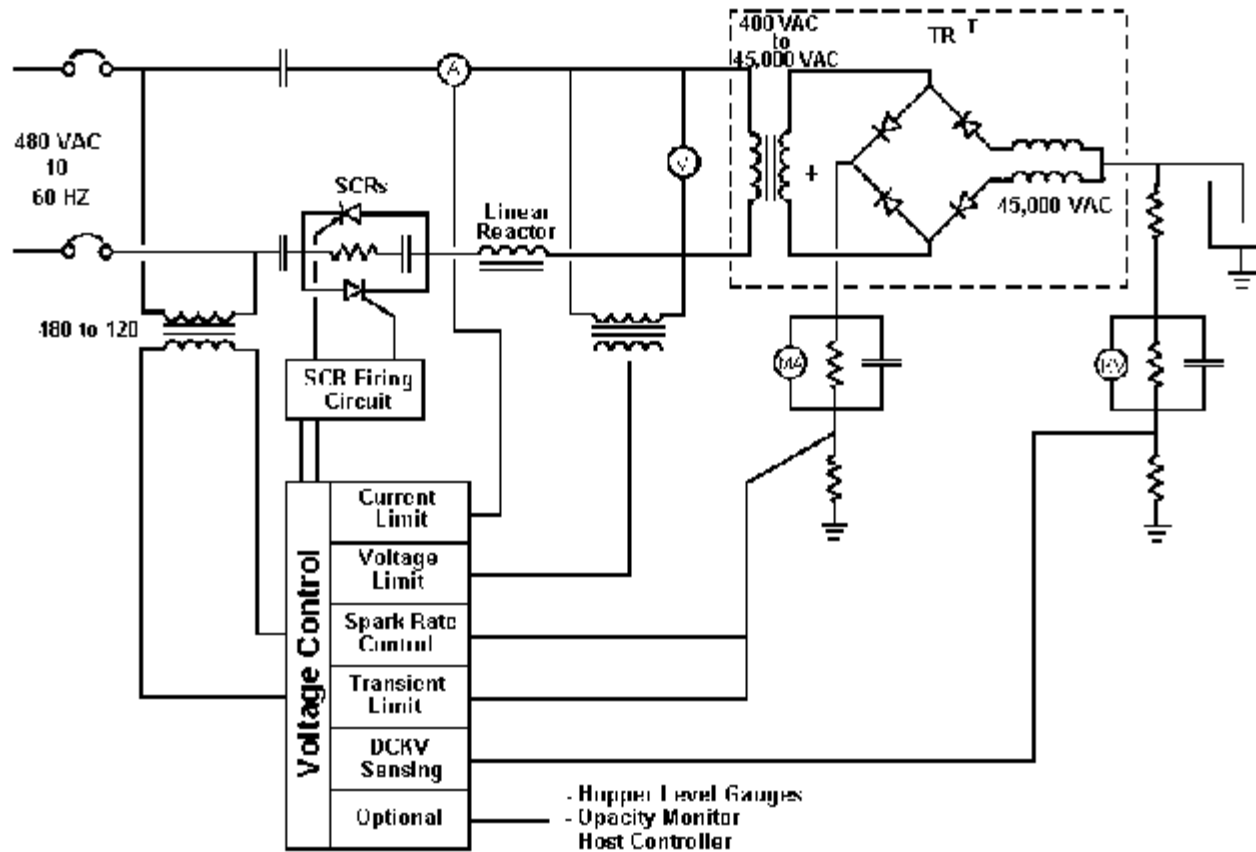

7/22/2018

2018 APC-Wastewater Conference



PRIMARY VOLTAGE

The "primary voltage" waveform is a chopped or pulsed sinusoidal waveform. It has been altered by the gating (turning on and off) of the SCRs.

Typically the waveform is not an actual representation of the actual voltage, because AC noise is suppressed on the signal.

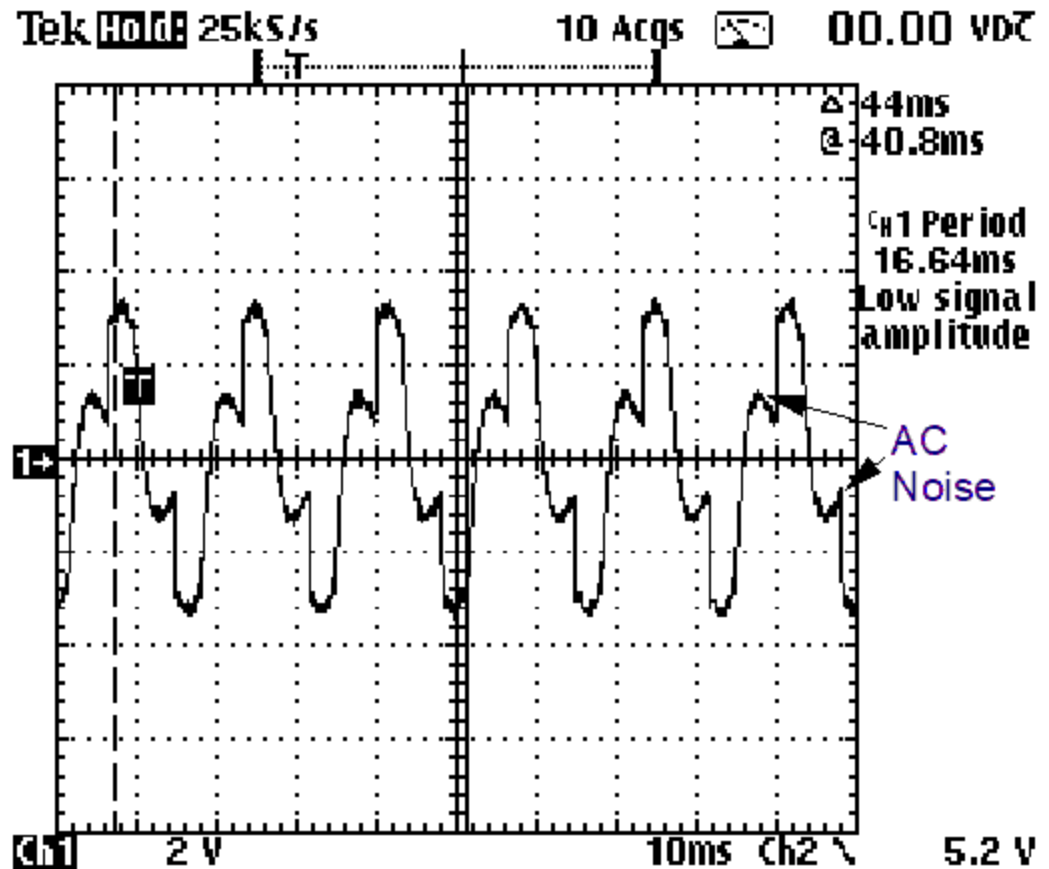

7/22/2018



PRIMARY CURRENT

The "primary current" waveform is a chopped sinusoidal waveform. It too has been altered by the gating of the SCRs. Here the off times are easily noted.

Typically the waveform originates from the current transformer and is normally an actual (clean) representation of the current.

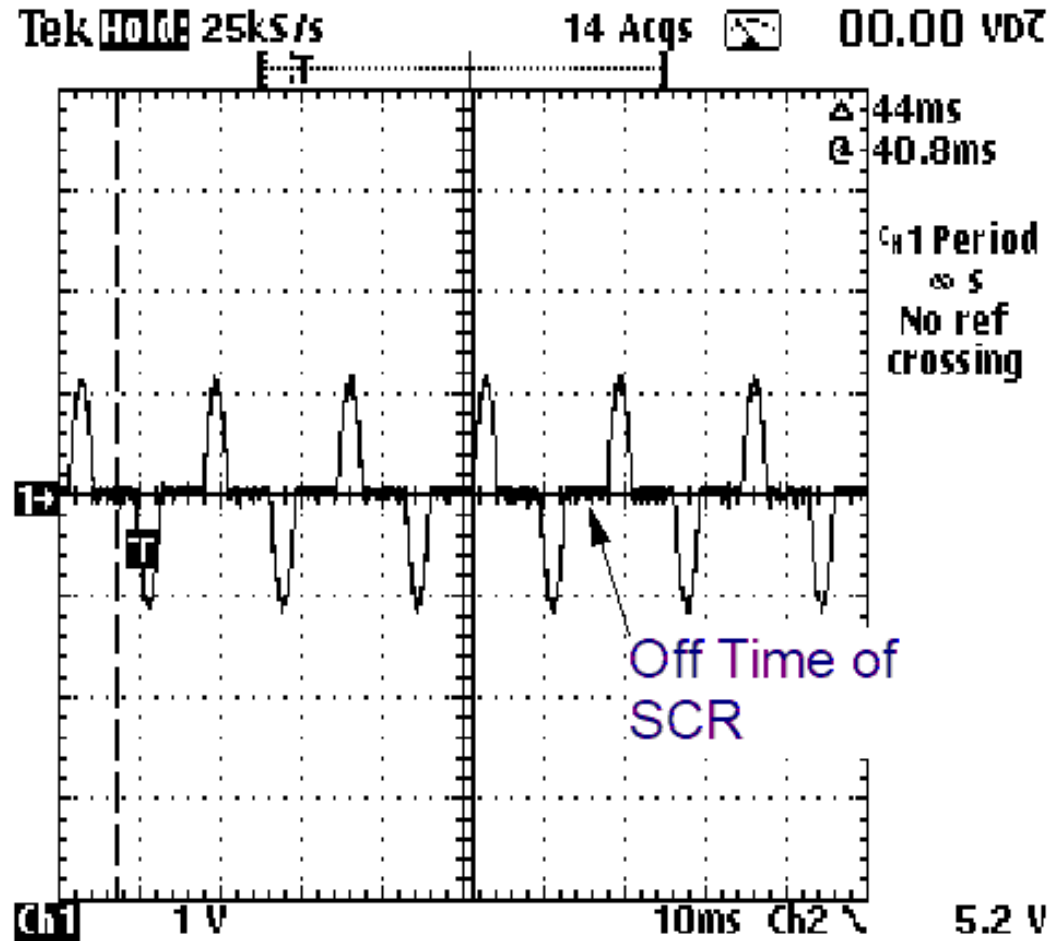

7/22/2018



SECONDARY VOLTAGE (TRUE NEGATIVE WAVEFORM)

The "secondary voltage" waveform is a saw tooth with sharp drops to zero when a spark occurs. The collapse is upward because the signal is a negative DC value.

The signal is a saw tooth because the ESP acts as a capacitor and decays between half cycles.

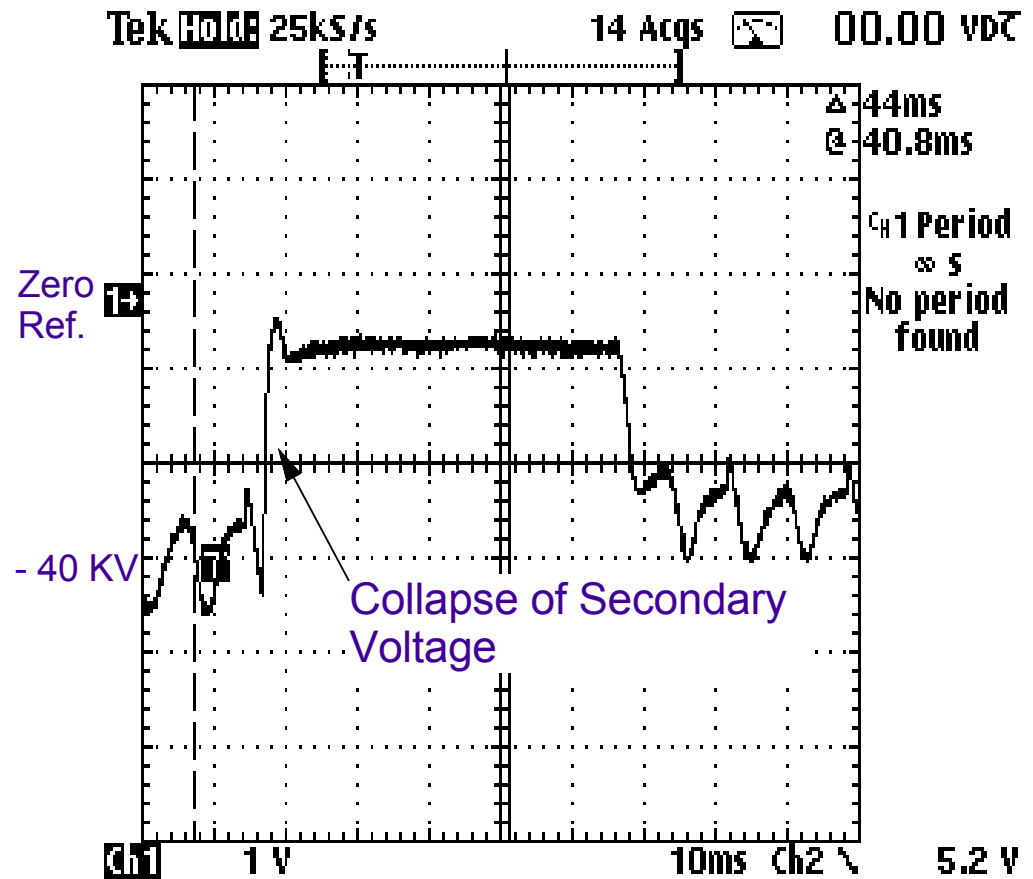

7/22/2018



SECONDARY VOLTAGE (SHOWN INVERTED)

The "secondary voltage" or KV waveform in this view is inverted. In this format the collapse is downward because the signal is a negative DC is represented as a positive value.

AEP typically displays the KV as an inverted signal, because it is easier to relate a collapse in voltage to a drop.

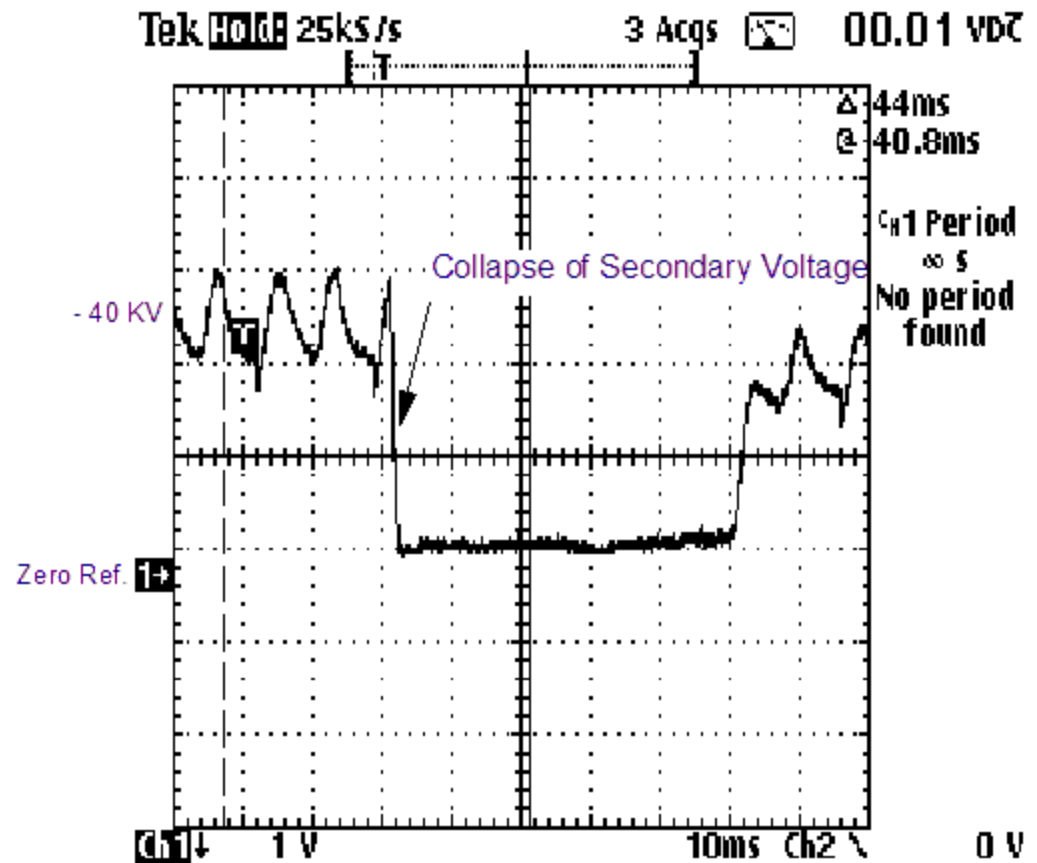

7/22/2018



SECONDARY CURRENT

The "secondary current" waveform is positive half cycle pulses. The pulses should occur every 8.33 ms since it originates from a rectified 60 cps input.

There are 2 half cycles per cycle.

$$\frac{1 \text{ Second}}{2 \times 60 \text{ Cycles}} = 8.33 \text{ ms}$$

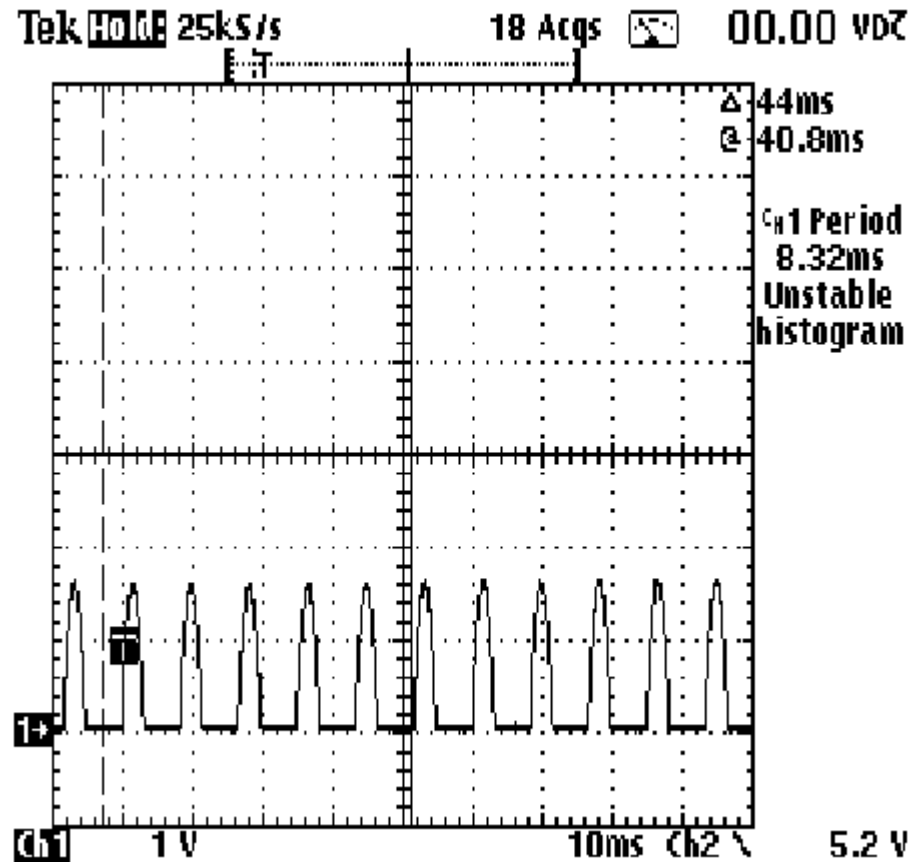

7/22/2018



ANALOG GATES SIGNALS

The waveforms are traces of the gate signals from an analog control.

An analog control sends alternating signals to only the SCR which corresponds to that half cycle which can pass current.

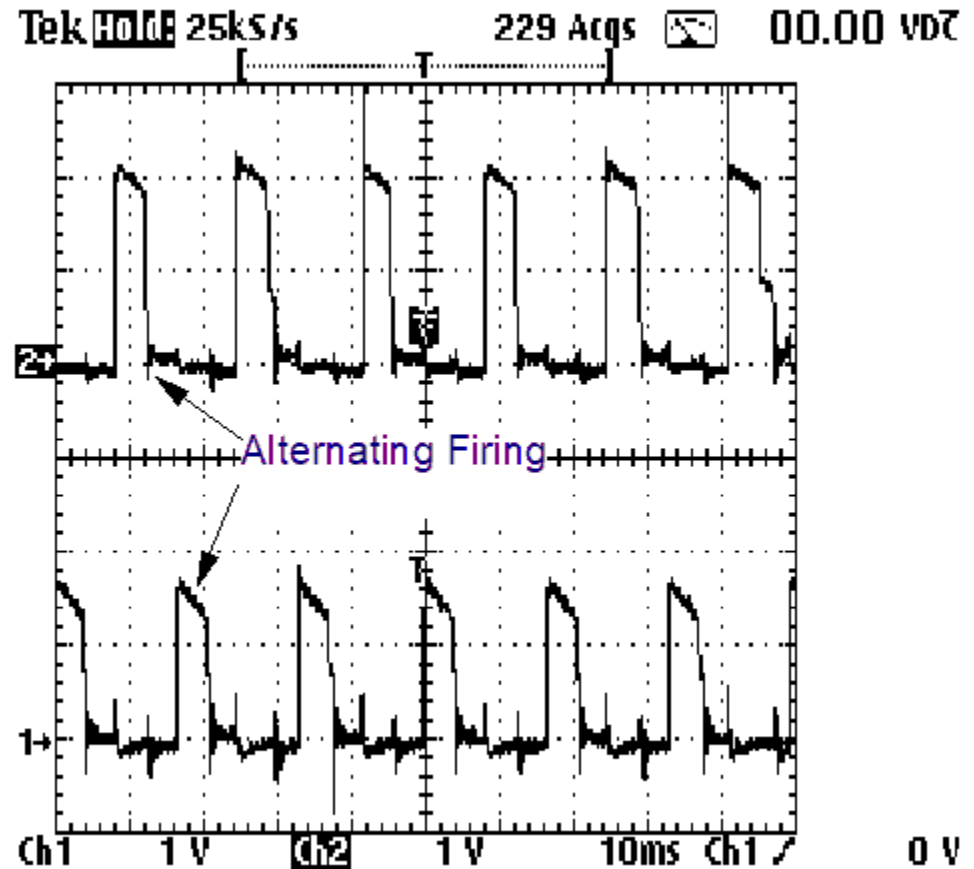

7/22/2018

2018 APC-Wastewater Conference

13



SHEL-B Environmental
Emissions Consulting, Inc.

DIGITAL GATES SIGNALS

The waveforms are traces of the gate signals from a digital control. A digital control sends simultaneous signals to both SCRs although only the SCR which corresponds to that half cycle passes current.

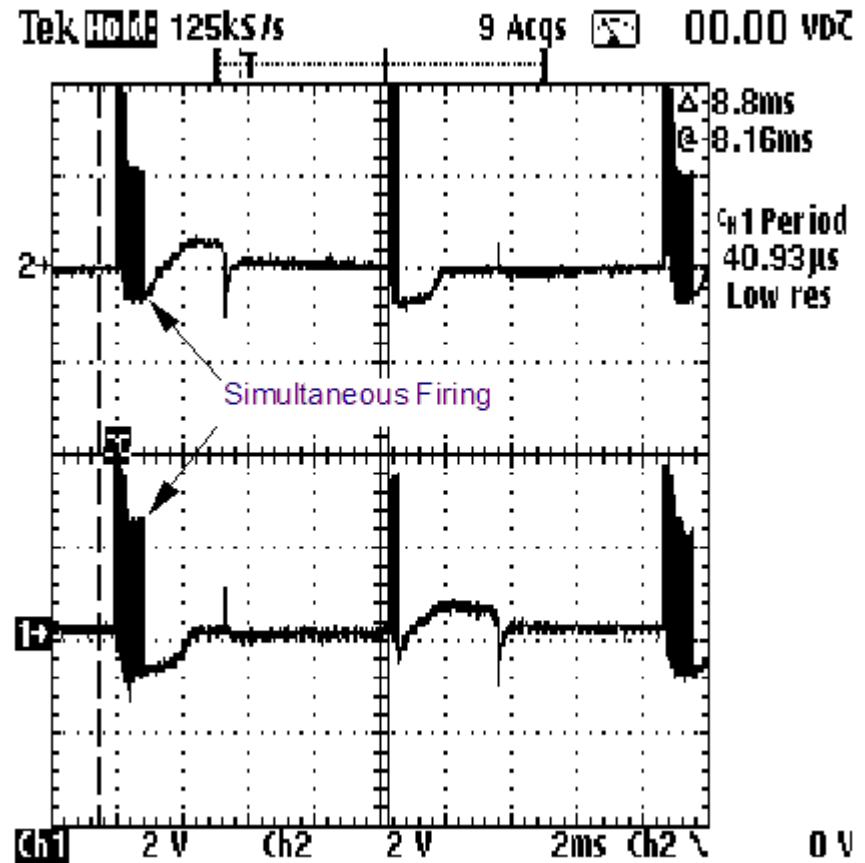
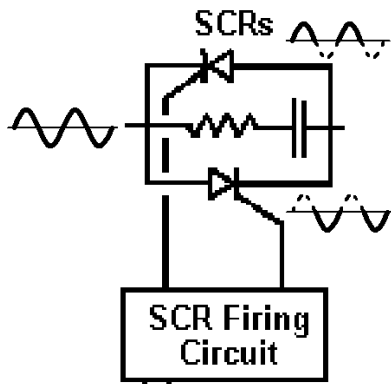

7/22/2018

2018 APC-Wastewater Conference

14



SHEL-B Environmental
Emissions Consulting, Inc.

TERMS FOR SECONDARY CURRENT

The terms used for a spark cycle are:

Steady State - operation prior to the spark (shown here as current limit)

Spark - a short circuit inside the ESP which disturbed the gases between the wire and plate.

Quench - a period of off time which allows the disturbed gas to be dissipated. (Typically 2 cycles)

Set Back / Spark Response - the differential between steady state and recovery operating level. (Typically 3 to 10%)

Recovery - a series of half cycles where the ESP returns quickly to near pre-spark conditions. (Typically 4 half cycles)

Slow Ramp / Rise Rate - the period of time it take the control to return to pre-spark level. The angle is based on set back and spark rate. Spark rate should never be greater than 60 sparks/minute (typically 10-30 spm for inlet sets and 1-10 spm for outlet sets)

Fast Ramp - a feature on some new controls where the control ramps quickly to induce a spark if one has not occurred based on the preset spark rate. This allows for quicker recovery after an upset inside the ESP.

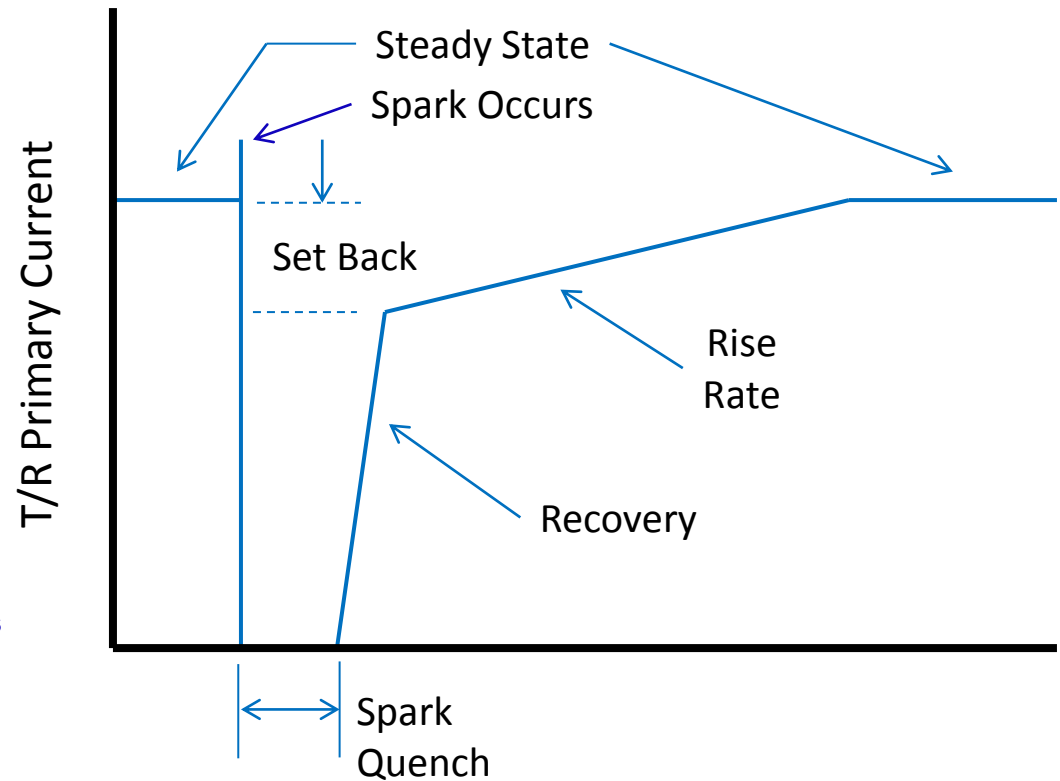

7/22/2018



TYPICAL SPARK RESPONSE

The waveform is a typical trace of a spark response for both secondary voltage (top - shown inverted) and secondary current (bottom). Note the collapse of secondary voltage when the spark occurred. The control quenched and then quickly recovered to a level below the spark point.

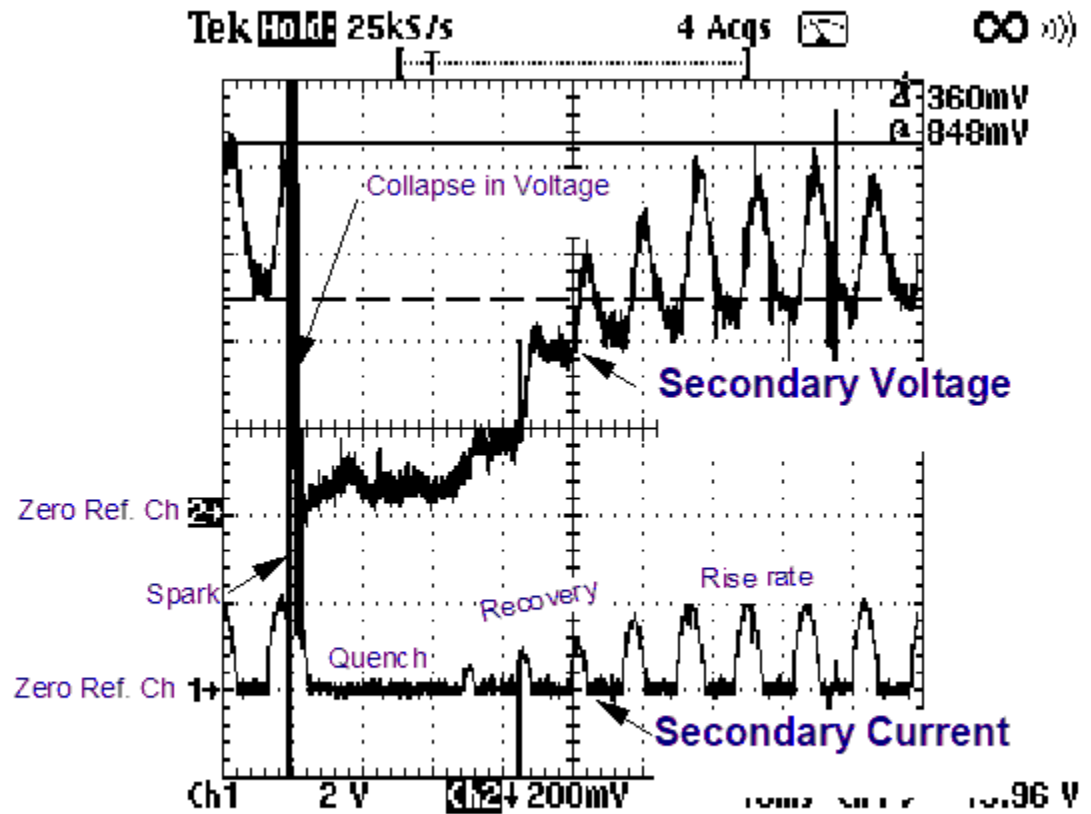

7/22/2018



AVC CONNECTION POINTS

WHEN TROUBLESHOOTING WITH A SCOPE

| Manufacturer | Secondary mA | Secondary KV | Primary Current | Primary Voltage | Gate Signal | Other |
|----------------------|---------------------------------------|---------------------------------------|---------------------------|-----------------------|--|---|
| ABB/Flakt EPIC I | 33/34 | 29/32 | N/A | N/A | LC 21/22 LC 23/24 | Supl. Gate Firing Card 7/8 & 9/10 |
| ABB/Flakt EPIC II | 48/49 | 64/65 | 50/51 | PT101 | LC 53/54 LC 55/56 | |
| ABB SIR A | 48/49 | 64/65 | 50/51 | 66/67 | LC 57/58 LC 59/60 LC 61/62 LC 63/64 | Supl. Gate Firing Card 1/2, 3/4, 5/6 & 7/8 |
| ABB SIR E | 15/16 | 17/18 | 1/2 | 3 / 4 | LC 27/28 | Supl. Gate Firing Card 1/2 & 5/6 |
| BHA SQ-300 | Connector J3 13/6 | Connector J3 10/6 | Connector J3 9/6 or CT | Connector J3 13/11 | Connector J2 9/10& 6/7 | |
| FLS miljo PIAVS | GTU X-12 35/36 | GTU X-12 36/37 | N/A | GTU X-1 1 / 4 | GTU X-15 5/6 | |
| Forry 3000/6000 | TB1 11/12 | TB1 13/14 | TB1 7/8 | TB1 9/10 | TB1 1 / 2 & 3 / 4 | Zero X TB1 5/6 |
| Forry 9000 | (A) P2 7/8 or R10 (B)P2 11/12orR12 | (A)P2 9/10 or R11 (B)P2 13/14orR32 | P2 3 / 4 or R7 | P2 5/6 or R8 | P1 1 / 2 P1 3 / 4 | Zero X P2 1 / 2 |

7/22/2018



AVC CONNECTION POINTS (CON'T)

| Manufacturer | Secondary mA | Secondary KV | Primary Current | Primary Voltage | Gate Signal | Other |
|-----------------------------|--|--|--|--|--|-------------------------------------|
| Lodge-Cottrell AVC IV SB | 7/14 | 6/14 | 4/14 | 5/14 | 22/23 | |
| NWL | TB1 5 to GND | TB1 3 to GND | TB1 2 to GND | TB1 1 to GND | J2 – 2/1 J2 – 5/4 | |
| R/C | 40/15 | 60/15 | C 13/15 | 6/7 or PT | FM 5(G)/6 9(G)/8 | Spark Sensing G SCR 501/15 |
| UOP | 2A/376 2B/376 | 1A/376 1B/376 | CT 32/34 Low Signal | K5/K4 | G1/K1 G2/K2 | |
| Neundorfer | Logic Board TP6 or Interface Board TP5/TP6 | A- LB TP7 or IB TP7/TP8 B –LB TP 8 or IB TP10/TP9 | Logic Board TP2 or Interface Board TP4/TP3 | Logic Board TP3 Interface Board TP1/TP2 | SCR 1 Across R11 SCR 2 Across R12 | Spark Sensing Logic Board TP9 |
| Wheelabrator | P3-22 | P3-23 | P3-21 | P3-19/P3-20 | P3-32 P3-33 | |
| RicoWerk | 1 Phase 6 to GND 3 Phase 18 to GND | 1 Phase 6 to GND 3 Phase 18 to GND | | | | |

7/22/2018



SCOPE RULES OF THUMB

Vertical - Channel #1

- Secondary mA
- DC coupled
- Bottom Trace or Signal
- Ground Reference
- 1 division from bottom
- 1 - 5 Volts/Div

Trigger

- Channel #1
- On Increasing Value
- Trigger Level - Variable
- May need HF filter

Vertical - Channel #2

- Secondary KV
- DC coupled
- Top Trace or Signal
- Ground Reference
- Center or 5 divisions from bottom
- 1 - 5 Volts/Div
- Inverted

Horizontal - Time

- 10 mS/Div

7/22/2018

2018 APC-Wastewater Conference

19



SHEL-B Environmental
Emissions Consulting, Inc.

FUN STUFF WITH A SCOPE

**Once you get comfortable with a scope,
you will never want to leave home
without it.**

7/22/2018

2018 APC-Wastewater Conference

20



SHEL-B Environmental
Emissions Consulting, Inc.

SPARK RESPONSE W/O SPARK

The waveform is a typical trace of a spark response for both secondary voltage (top - shown inverted) and secondary current (bottom). Note the collapse of secondary voltage when the spark occurred. The control quenched and then quickly recovered to a level below the spark point.

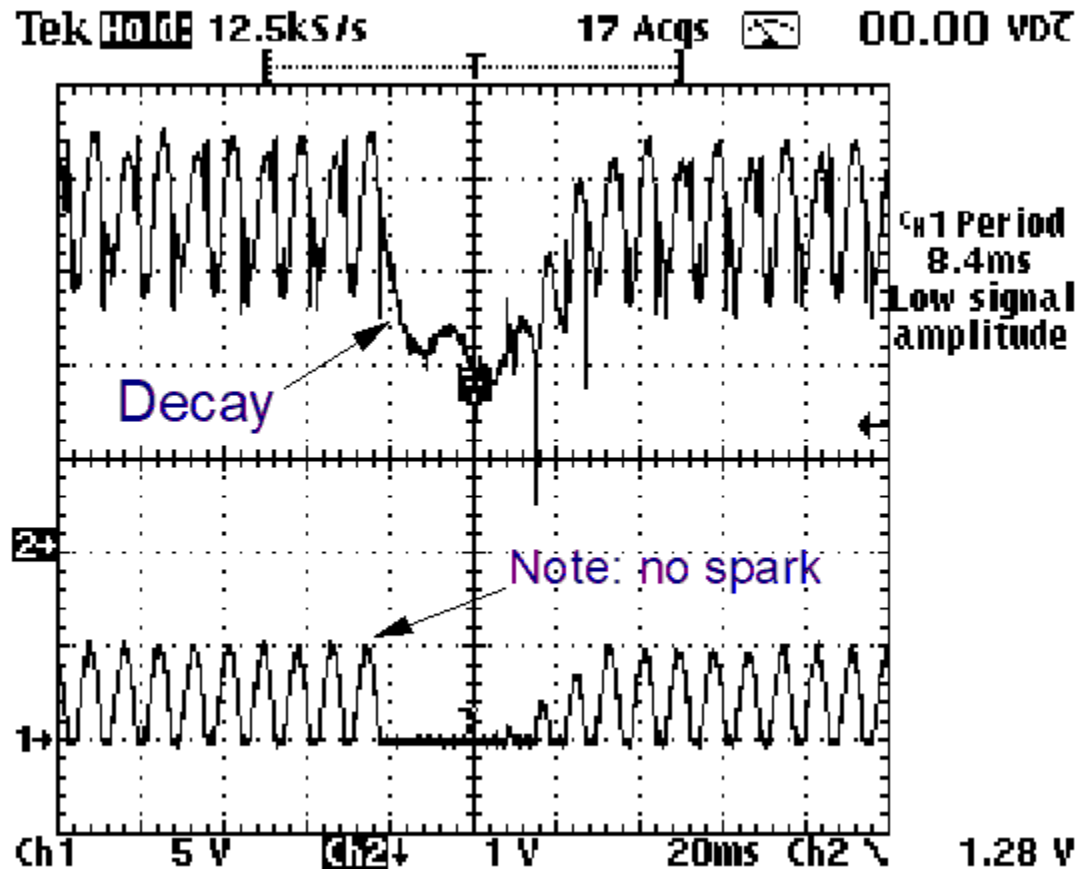

7/22/2018



ASH RESISTIVITY

- ❑ Fly ash resistivity/conductivity determined by two independent mechanisms
 - Volume resistivity/conduction
 - Surface resistivity/conduction
- ❑ Volume resistivity due to conduction through the bulk of the fly ash
- ❑ Volume resistivity dominates at higher temperatures

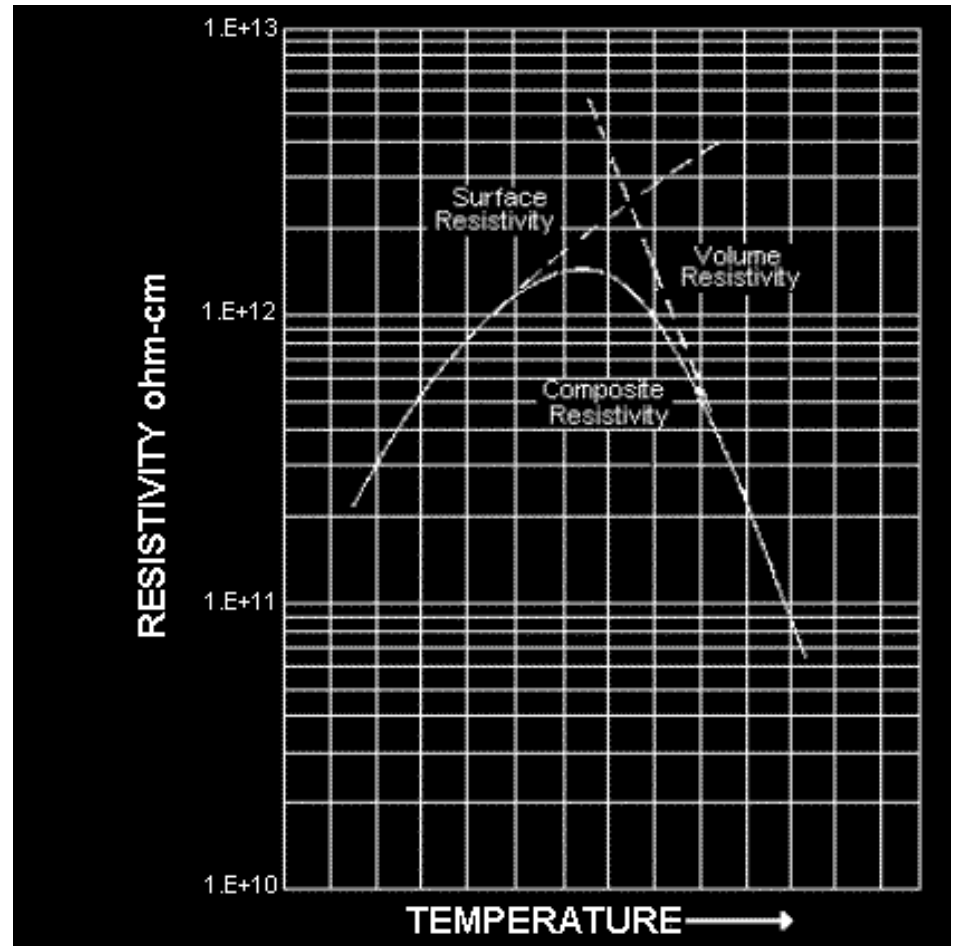

7/22/2018

2018 APC-Wastewater Conference



TYPICAL WAVEFORM VS. BACK CORONA

The two waveforms are photos of a spark response for both secondary voltage (top - shown inverted) and secondary current (bottom). Note the rise and leveling of secondary voltage after the spark in the upper photo after the spark occurred. This is the expected response after a spark.

The lower photo shows control setting where the secondary voltage rises but then drops as the current continues to increase. This is a sign that "back corona" or reverse ionization is present.

Scope Trace Showing
A Typical Spark Response

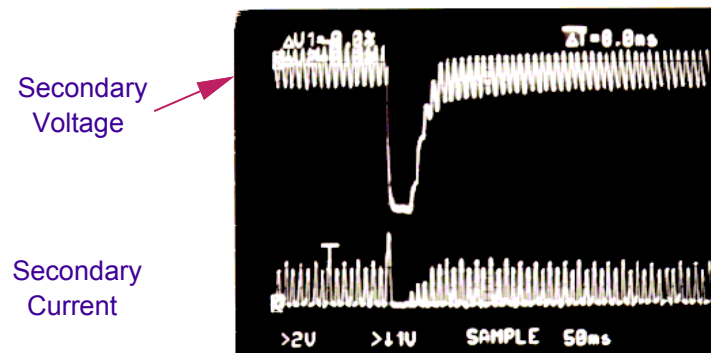

Scope Trace Showing
Back Corona

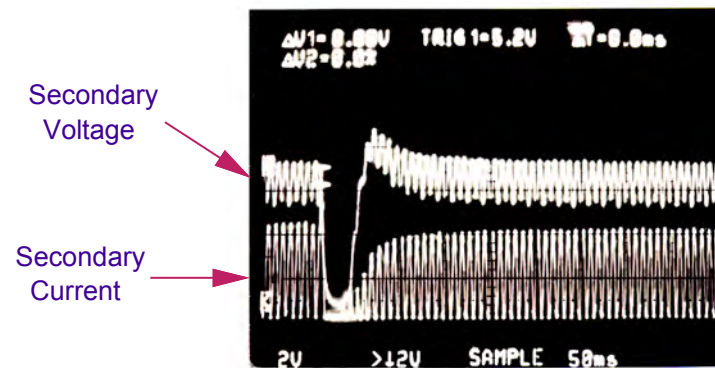

7/22/2018

2018 APC-Wastewater Conference

23



SHEL-B Environmental
Emissions Consulting, Inc.

ADDITIONAL SCOPE TRACES OF BACK CORONA

The two scope traces shown here also have signs of back corona. The upper trace has the classic decay in the trough of the KV signal indicating back corona. However it has a second symptom which is a spread between the peaks and troughs as time progresses. Both of the symptoms of back corona noted here at easily noted.

The lower scope trace is a little more difficult to observe the back corona symptoms. If one only looks at the post spark portion of the waveform, it is difficult to note the back corona. However if the steady state condition before the spark is evaluated, it can be seen that the spread between the peak and troughs have increased over time as well as the decay in the troughs. Both are signs that this bus section is in the early stages of back corona.

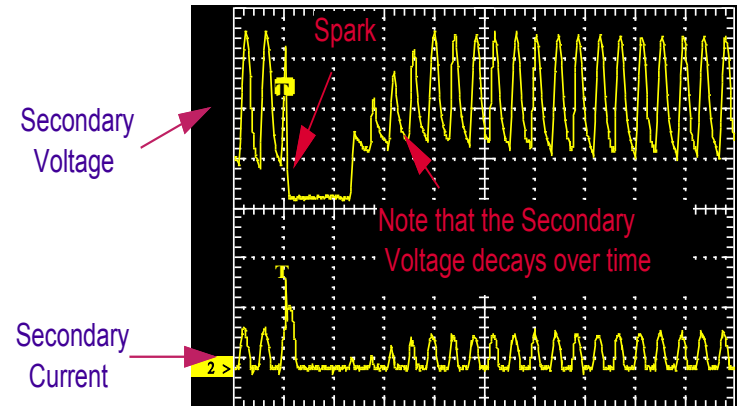

1) Ch 1: 50 V 20 ms
2) Ch 2: 50 V 20 ms

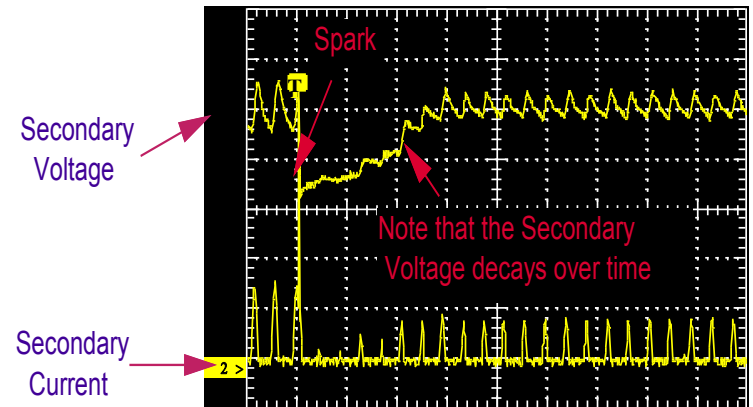

1) Ch 1: 10 V 20 ms
2) Ch 2: 10 V 20 ms

7/22/2018

2018 APC-Wastewater Conference

24



SHEL-B Environmental
Emissions Consulting, Inc.

CORONA DISCHARGE

Photo of corona discharge from a straight weighted wire electrode. The non-uniform discharge is due to imperfections in the surface of the electrode.

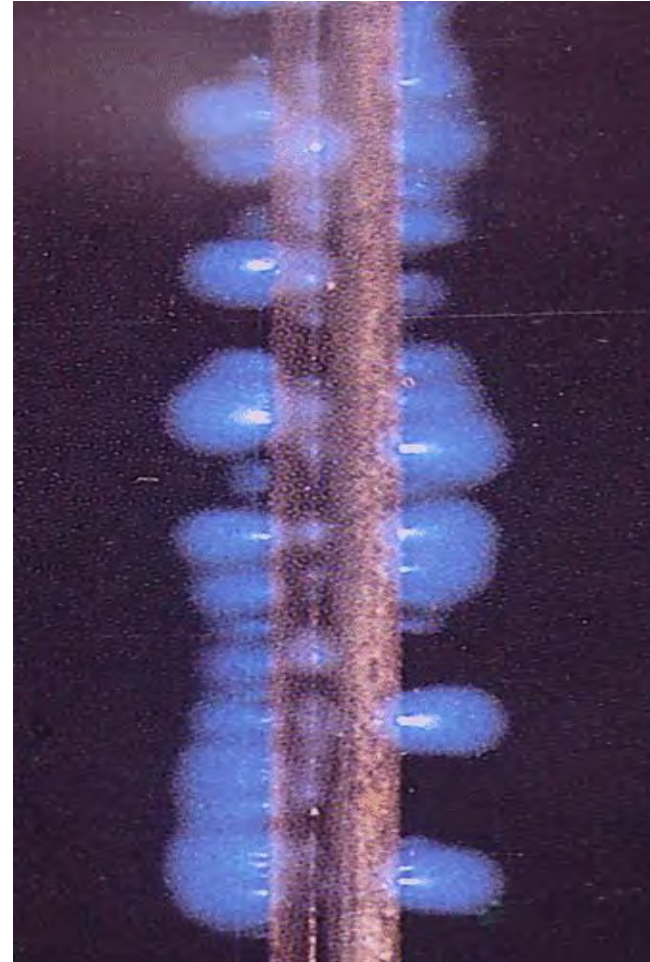

7/22/2018

2018 APC-Wastewater Conference

25



SHEL-B Environmental
Emissions Consulting, Inc.

CORONA DISCHARGE

Photo of corona discharge from a barbed weighted wire electrode. Note that the barbs allow for a more uniform corona discharge.

Photo courtesy of Southern Company.

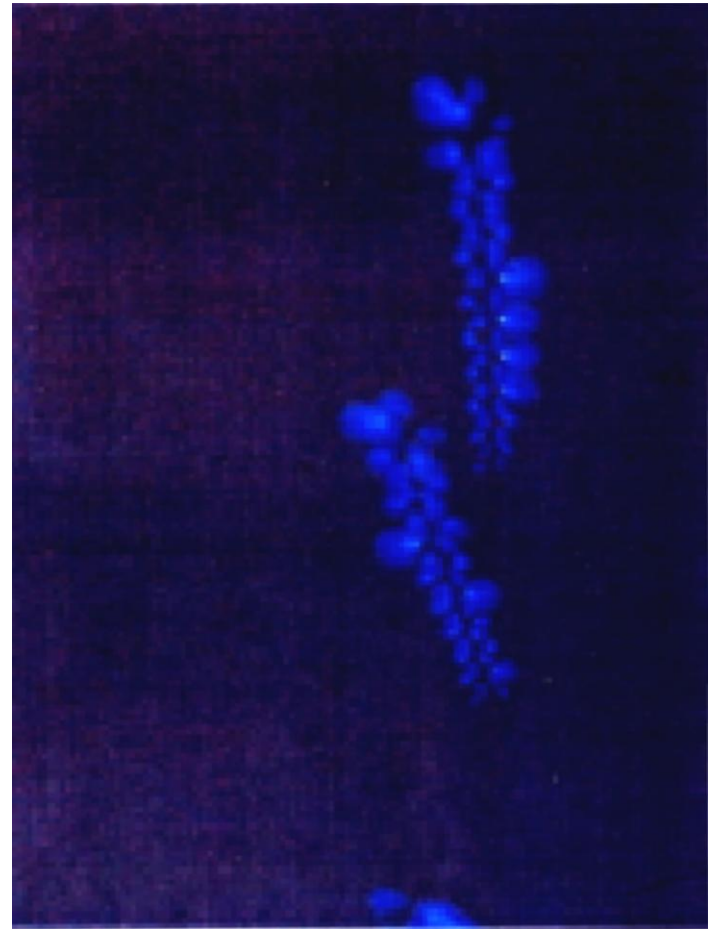

7/22/2018

2018 APC-Wastewater Conference

26



SHEL-B Environmental
Emissions Consulting, Inc.

BACK CORONA

Photo of corona discharge from a barbed weighted wire electrode with back corona developing at the plate.

Photo courtesy of Southern Company.

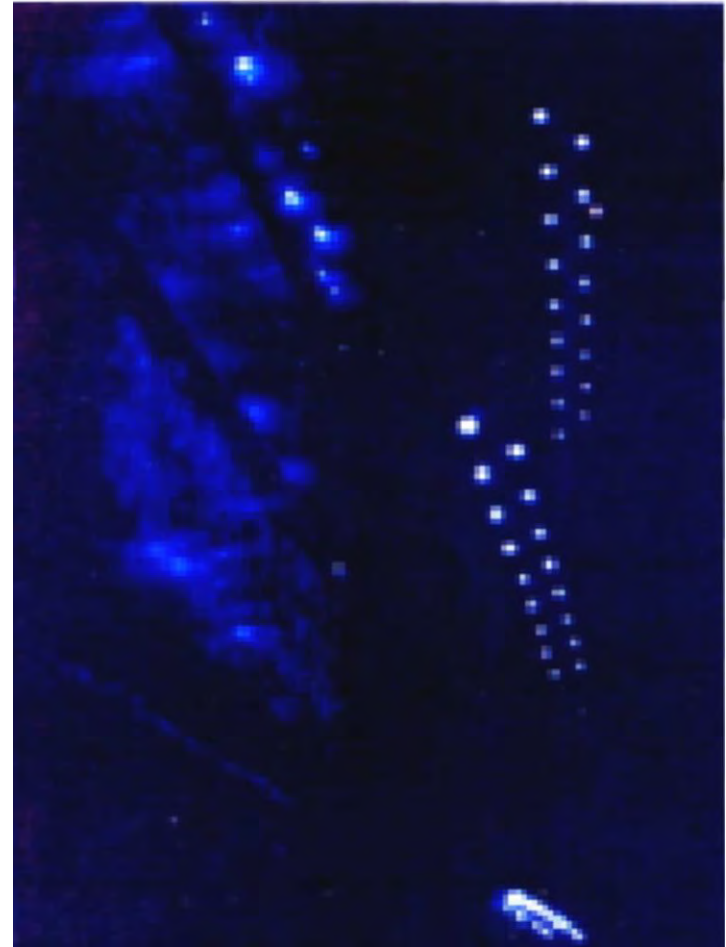

7/22/2018

2018 APC-Wastewater Conference

27



SHEL-B Environmental
Emissions Consulting, Inc.

SECONDARY SIGNALS W/ONLY 1 SCR FIRING

The waveform is a trace of the secondary voltage and current. The significance of this trace is that the period of the half cycles is 16.67 ms.

The period should be 8.33 ms. Since the secondary voltage signal corresponds to the current signal, one of the SCRs is not firing.

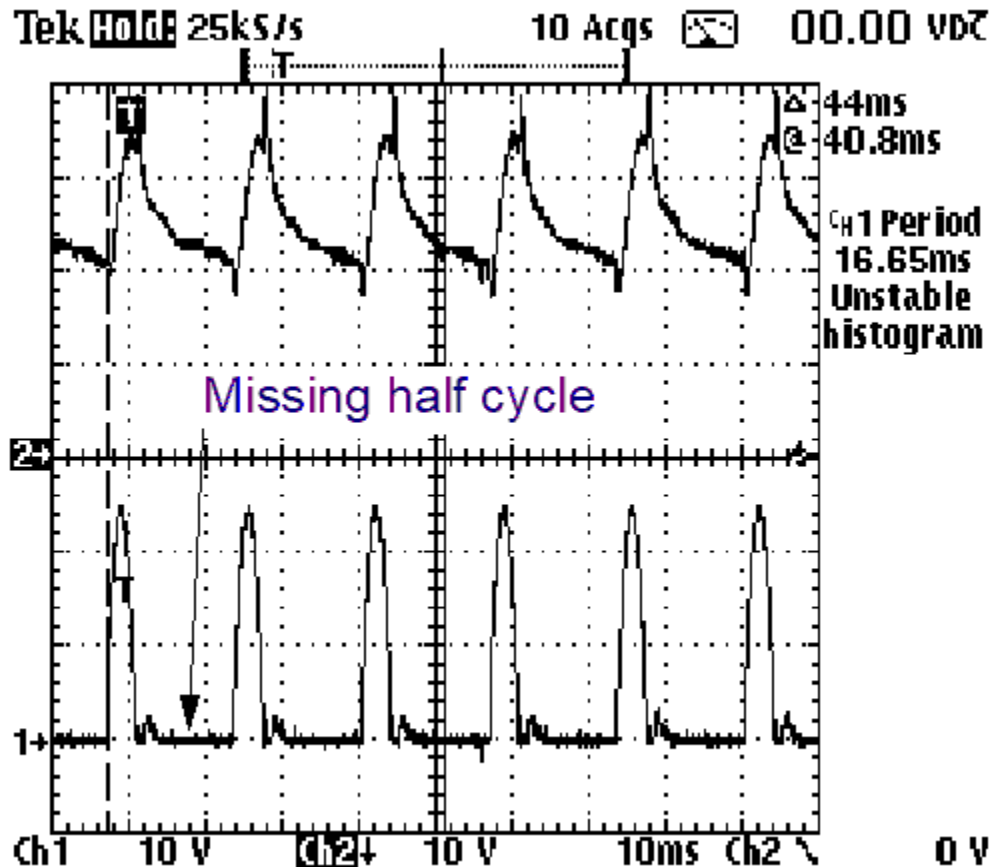

7/22/2018

2018 APC-Wastewater Conference

28



SHEL-B Environmental
Emissions Consulting, Inc.

SECONDARY CURRENT FEEDBACK MISSING ONE LEG OF BRIDGE

The waveforms are traces of the secondary voltage and current. The significance of this trace is that the period of the current half cycles is 16.67 ms. The period should be 8.33 ms. However, the secondary voltage signal does not correspond to the current signal. Since there are voltage pulses where the current pulses are missing this indicates a signal feedback problem.

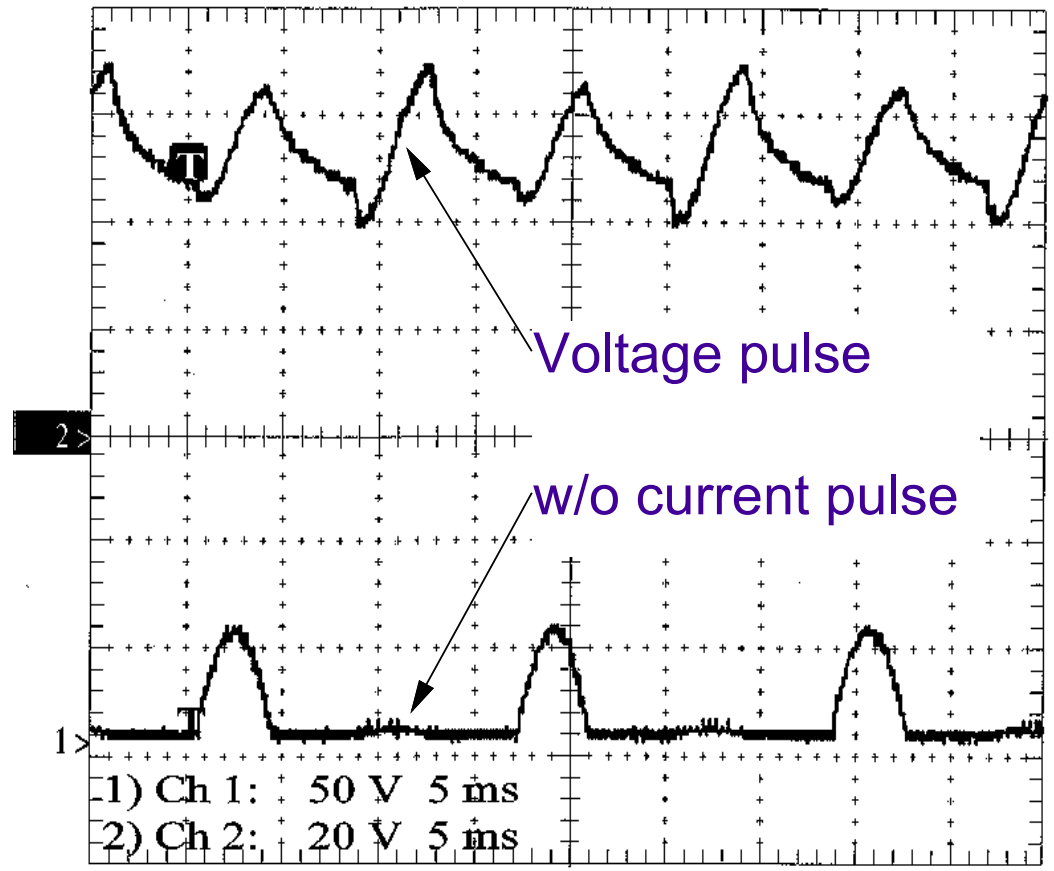

7/22/2018



ANALOG GATE PULSE VS. SEC. CURRENT W/AN SCR NOT FIRING

The waveforms are traces of an analog gate signal and current. The purpose of this trace is to aid in determining which SCR is not firing and if the control is telling the SCR to fire. This will identify what part of the circuit is a problem.

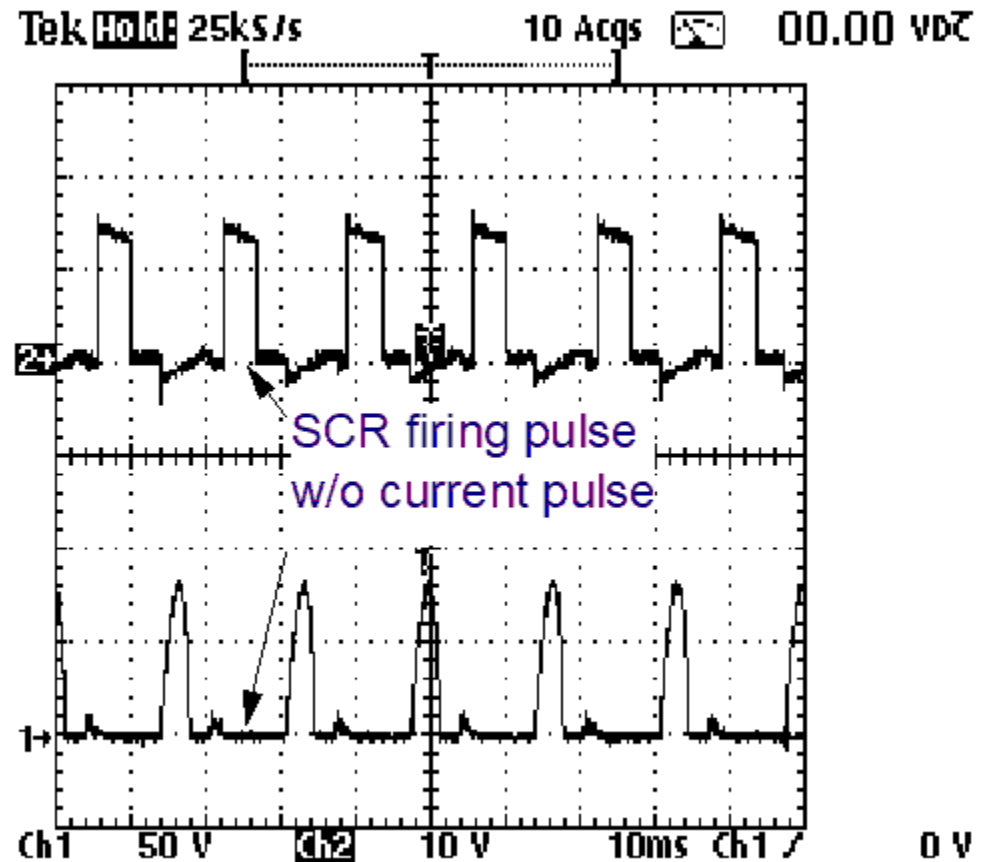

7/22/2018

2018 APC-Wastewater Conference

30



SHEL-B Environmental
Emissions Consulting, Inc.

SCR FIRING WITH RESPECT TO ZERO CROSSING

An SCR, once gated (turned on) continues to be gated (flows current) until current flow stops. In an AC circuit current flow stops when the direction of current changes. Since the SCR are utilized on the AC portion of the controls circuit, TR set controls have an input for the AC feed to determine when current flow passes through zero on the direction change. This signal, because of its reference to current passing through zero, is known as “Zero Crossing”. The control bases its firing of the SCRs off of the Zero Crossing reference.

The SCRs are turned on by a series of pulses to their gates. The control establishes a buffer zone between Zero Crossing and the firing pulses, whether it fires early or late into the half cycle. This buffer zone is to ensure that the SCRs are always firing before the half cycle reaches Zero Crossing. If the SCR firing pulses occur while going through Zero Crossing, the SCR associated with the next half cycle will immediately fire. This will result in high, unwanted current flow which increases the voltage rapidly thus creating a major spark in the bus section.

- 1) Ch 1: 100 mV 2 ms
- 2) Ch 2: 100 mV 2 ms
- 3) Ref A: 20 V 2 ms
- 4) Ref B: 5 V 2 ms

Late Firing

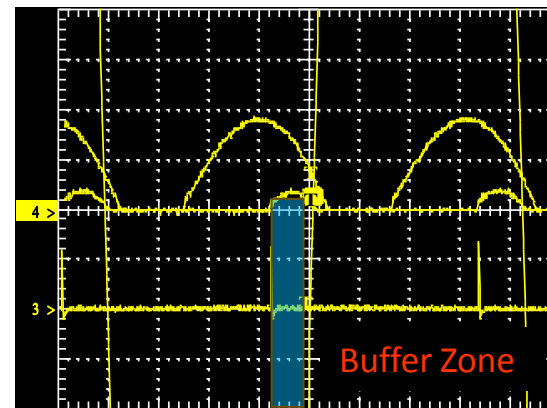

Early Firing

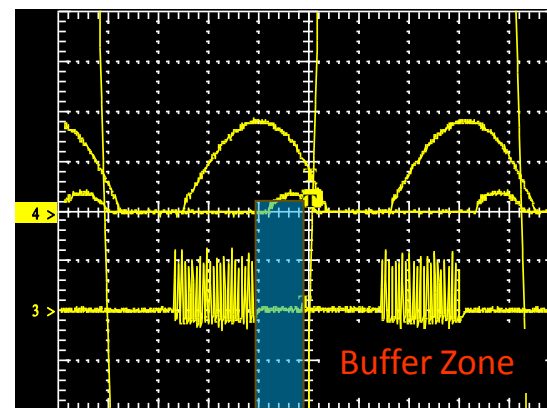

- 1) Ch 1: 100 mV 2 ms
- 2) Ch 2: 100 mV 2 ms
- 3) Ref A: 20 V 2 ms
- 4) Ref B: 5 V 2 ms

7/22/2018



RINGING ON DUAL BUSHING TRS IF CHOKES ARE AFTER CROSS-TIE

The waveforms are traces of the secondary voltage and current. The significance of this trace is that ringing (a continuance of a spark) is occurring after the spark. The ringing occurs because inductive chokes are installed downstream of the full wave link between bushing on a dual bushing TR set.

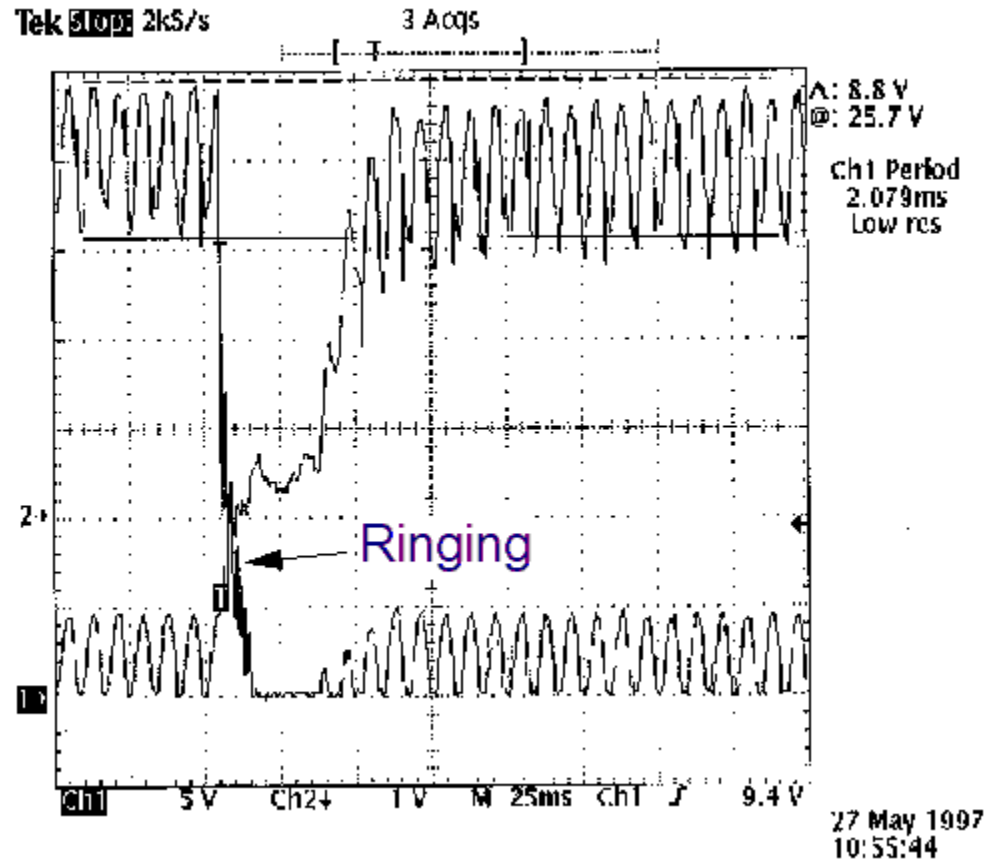
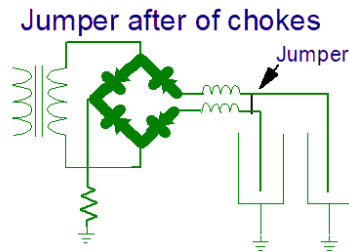
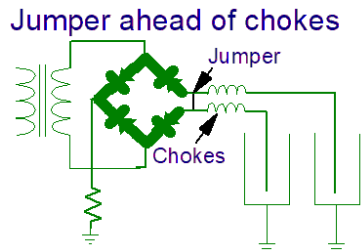

7/22/2018

2018 APC-Wastewater Conference

32



SHEL-B Environmental
Emissions Consulting, Inc.

SPARK SENSING CIRCUIT DETECTING A SPARK

The waveforms are traces of the spark sensing circuit and the secondary current. When a spark occurs the capacitor in the sensing circuit holds the signal through a long discharge so sparks are not missed. This ensures a spark (because it is narrow) is not missed during the digital sampling of the current wave form.

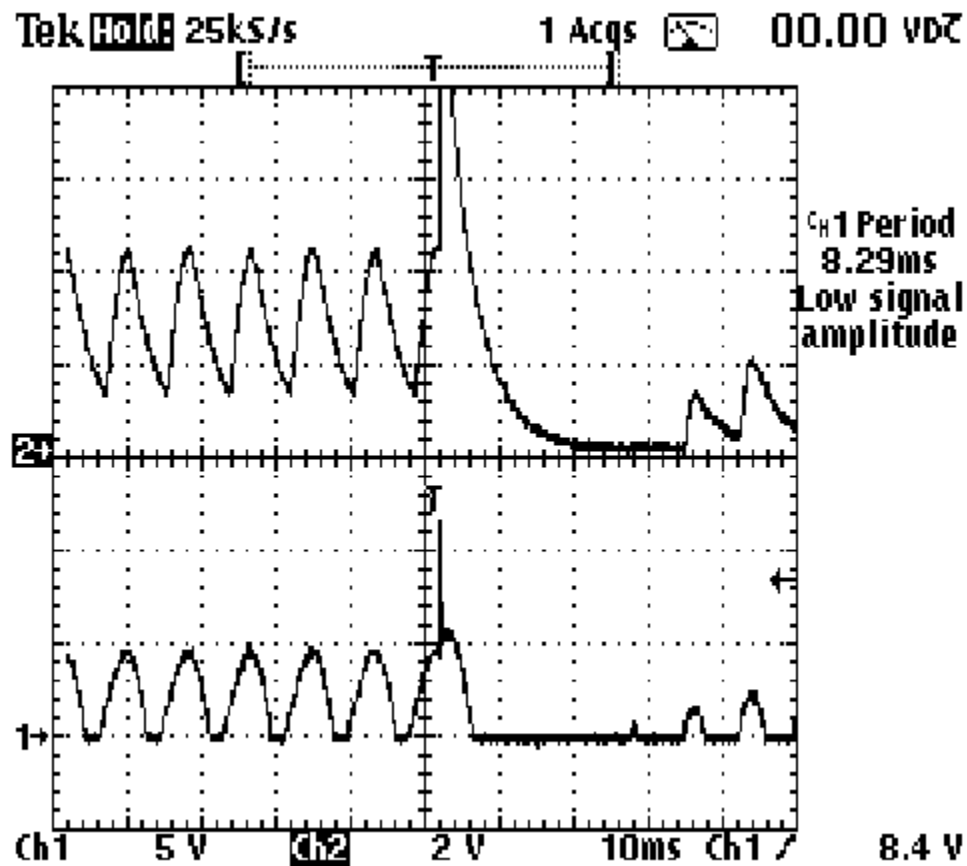
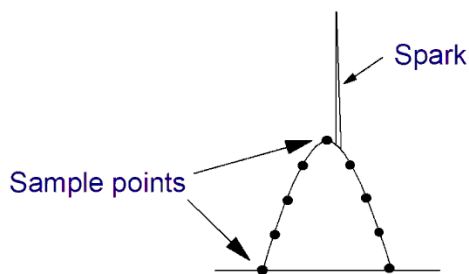

7/22/2018



T/R SET DIODE BRIDGE FAILURE

Abnormal Secondary Current

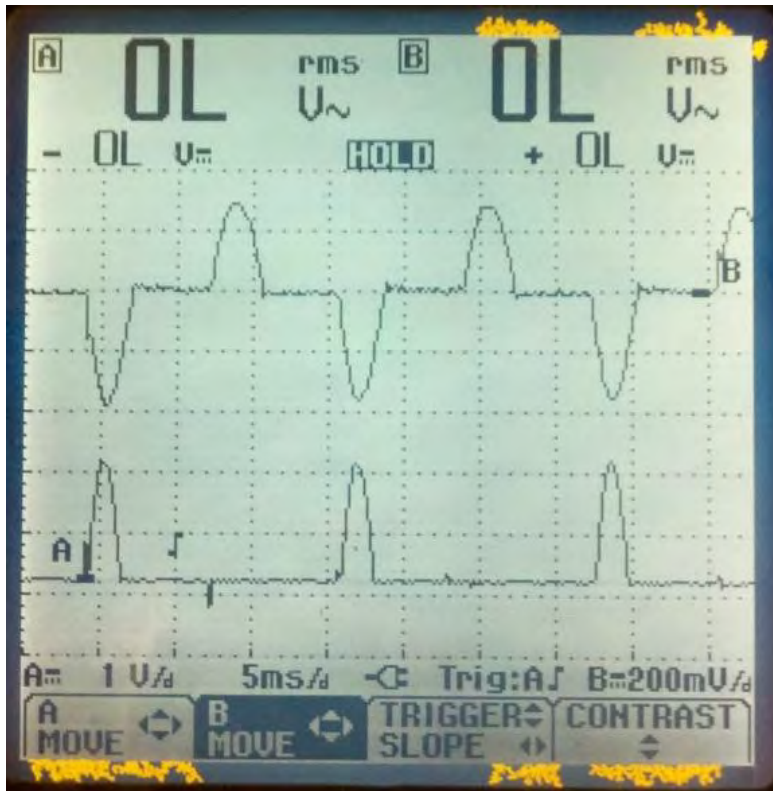

Abnormal Secondary Voltage

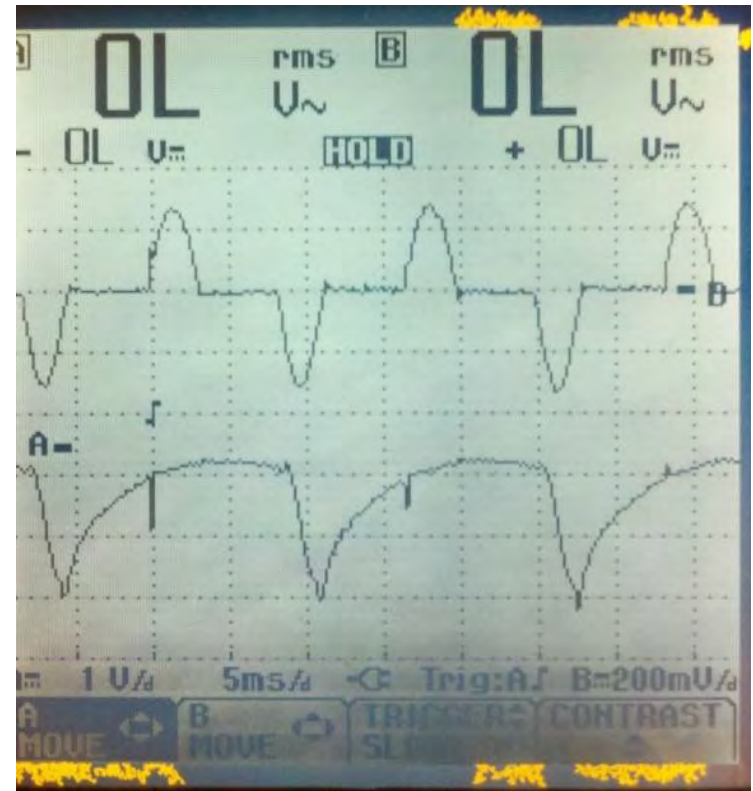

Scope traces courtesy of Southern Company.

7/22/2018

2018 APC-Wastewater Conference

34



SHEL-B Environmental
Emissions Consulting, Inc.

SUSPECT DIODE STACK

The waveforms are traces comparing the secondary current of reference T/R set versus suspect T/R set. With reference set powered down to equal the output of suspect set. The wave form indicates that the on-time and peaks are about the same therefore the CLR should be OK. The edges of the SCR firing are not at 90° therefore the diode stacks may be going soft.

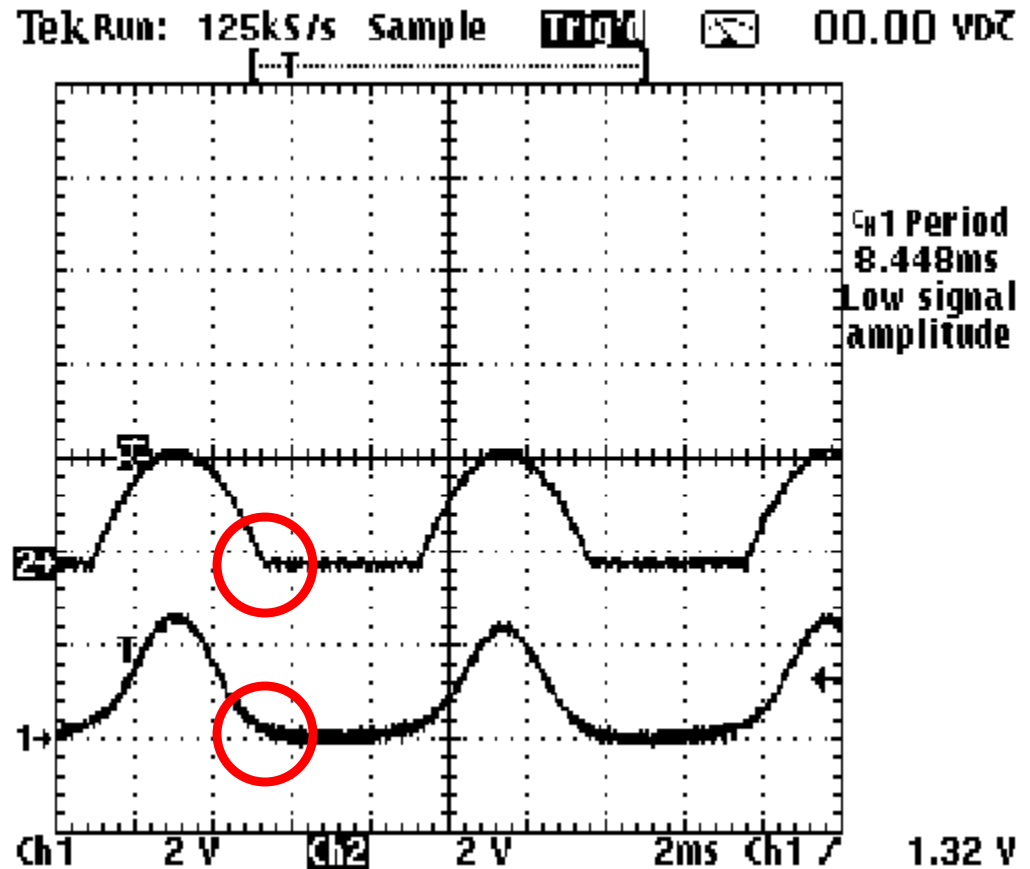

7/22/2018

2018 APC-Wastewater Conference

35



SHEL-B Environmental
Emissions Consulting, Inc.

PURPOSE OF A LINEAR REACTOR

No Linear Reactor

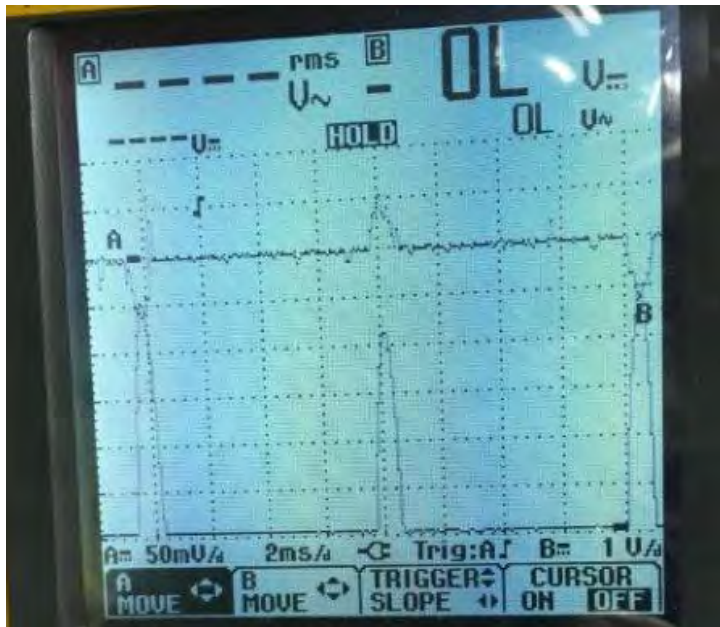

w/Design Linear Reactor

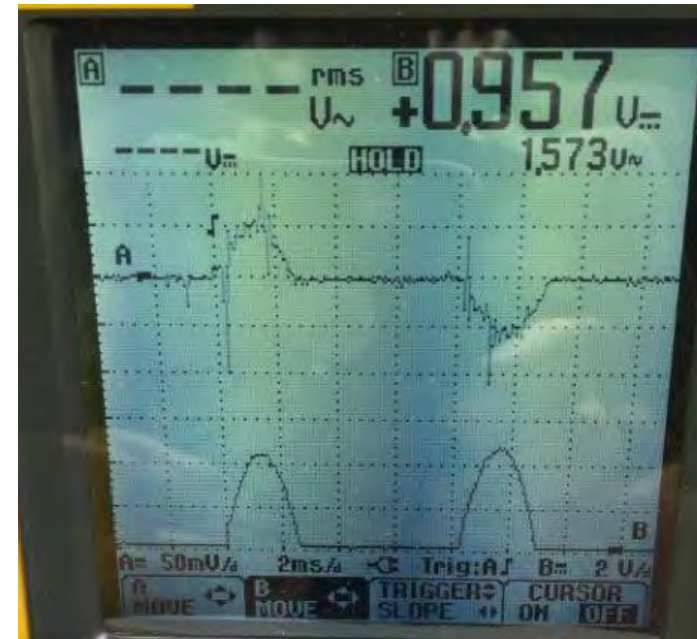

Scope traces courtesy of Southern Company.

7/22/2018

2018 APC-Wastewater Conference

36



SHEL-B Environmental
Emissions Consulting, Inc.

SUSPECT CURRENT LIMITING REACTOR

The waveforms are traces comparing the secondary current of reference T/R set versus suspect T/R set. With reference set powered down to equal the output of suspect set, the wave form indicates that the on-time is shorter than the reference bus section and peaks are higher. The RMS appears to be a bit higher than the reference section. The CLR is suspect. The edges of the SCR firing are at 90° therefore the diode stacks should be OK.

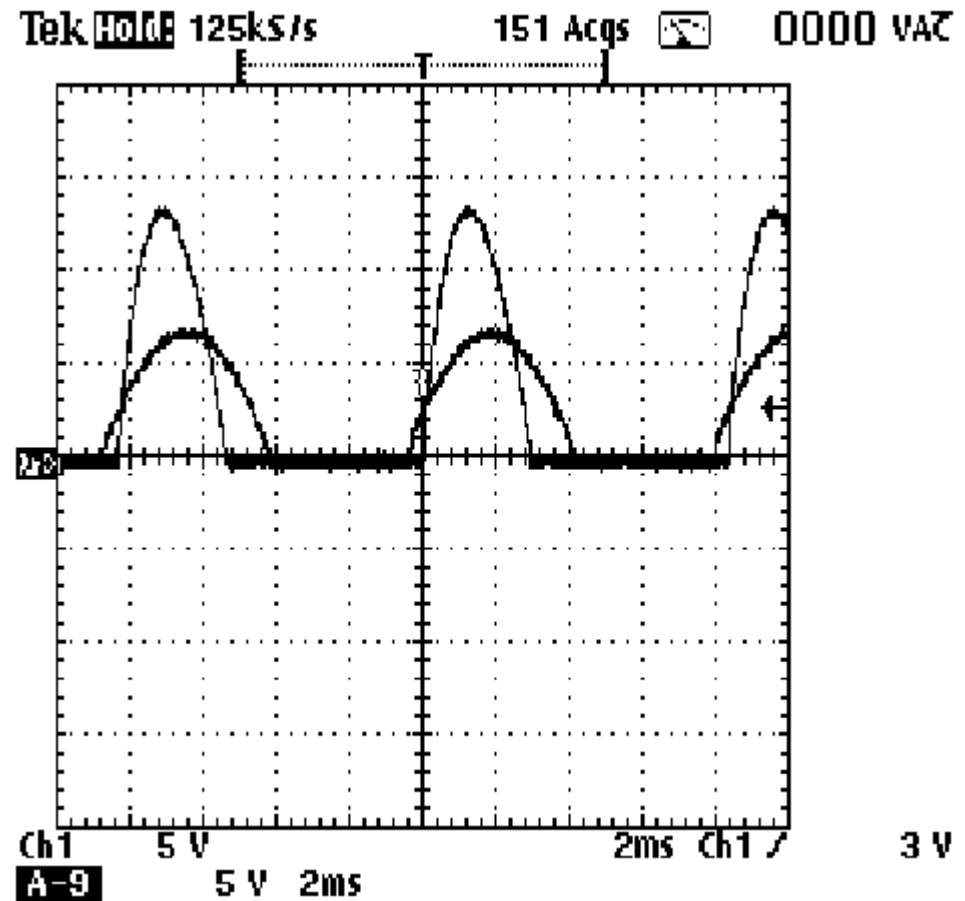

7/22/2018

2018 APC-Wastewater Conference

37



SHEL-B Environmental
Emissions Consulting, Inc.

SUSPECT CURRENT LIMITING REACTOR

The waveforms are traces comparing the secondary current of reference T/R set versus suspect T/R set. With reference set powered down to equal the output of suspect set, the wave form indicates that the on-time is longer than the reference bus section and peaks are lower. The RMS appears to be about the same therefore the CLR is suspect. The edges of the SCR firing are at 90° therefore the diode stacks should be OK.

7/22/2018

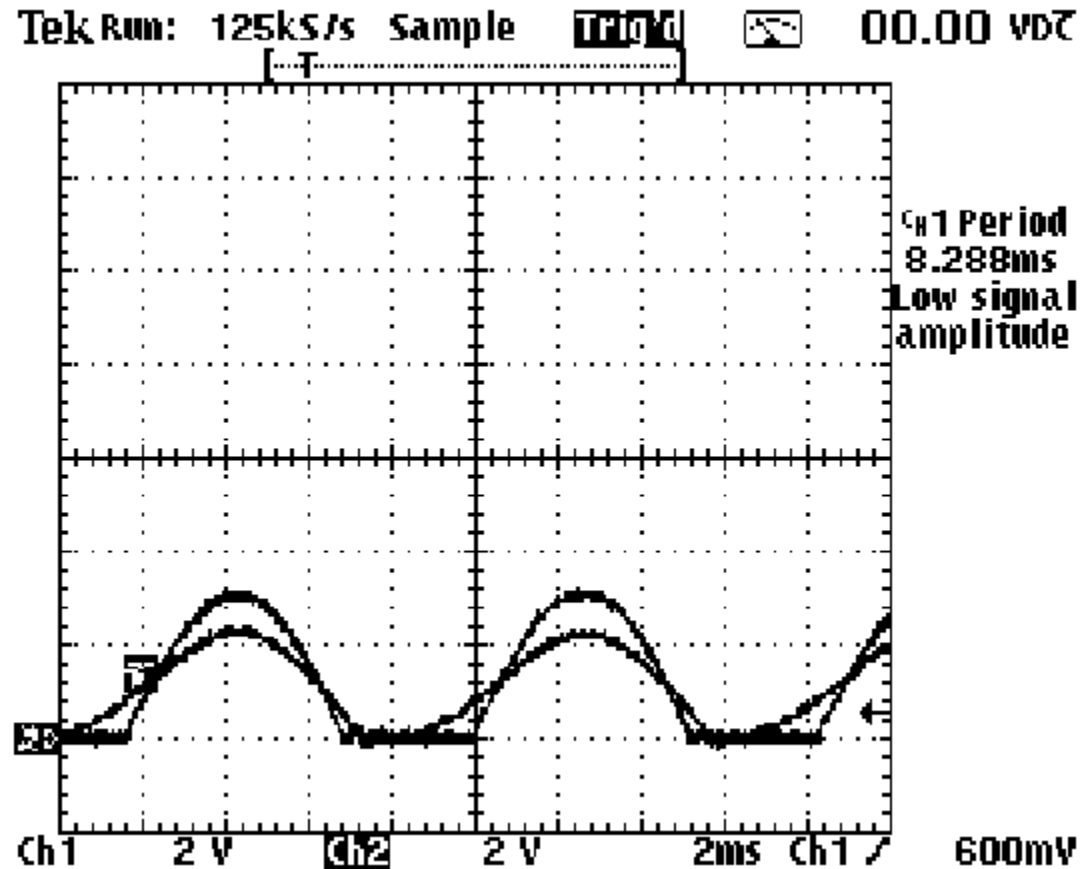

EVALUATING CLRS PER FIELD

The “Secondary Current” waveform is shown here just looking at a single half cycle for four fields in direction of gas flow.

The yellow signal is the inlet field and has a late firing, whereas the green signal is an outlet field having an earlier.

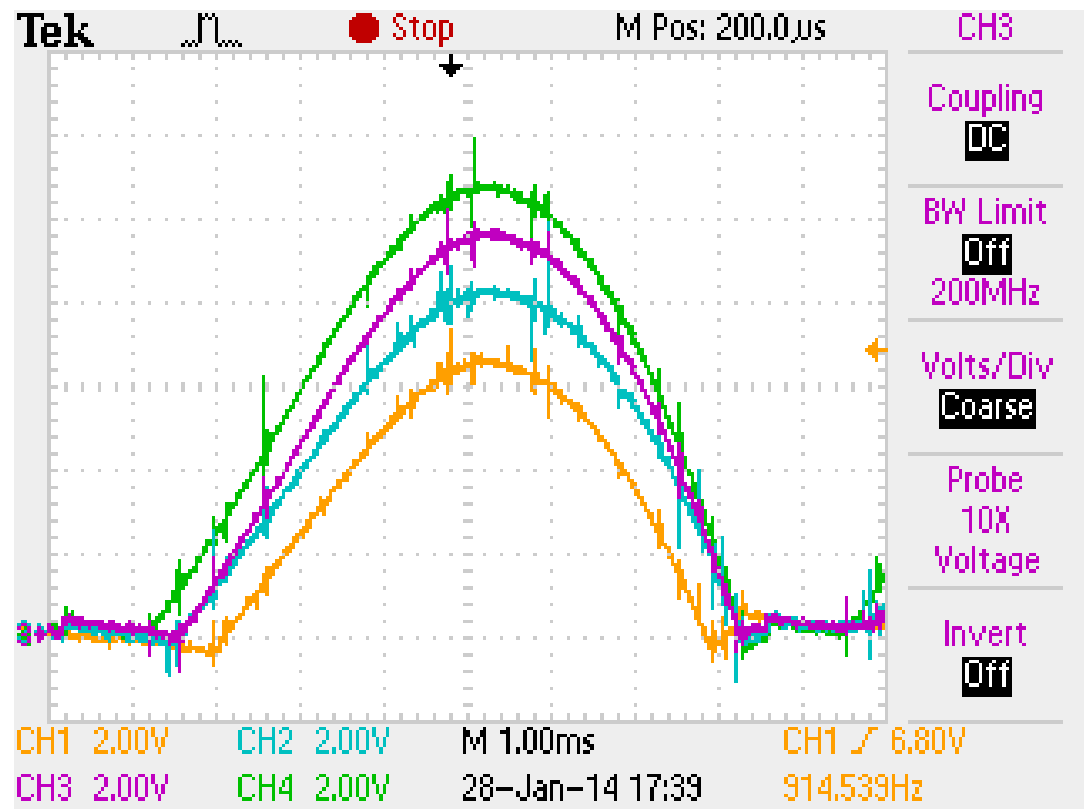

7/22/2018

2018 APC-Wastewater Conference

39



SHEL-B Environmental
Emissions Consulting, Inc.

EVALUATING SPARKING PER FIELD

The "Secondary Current" waveform is shown here just looking at a numerous half cycles for four fields in direction of gas flow.

The purpose of this collection of waveforms is to verify that an inlet spark does not propagate into successive sparks in direction of gas flow.

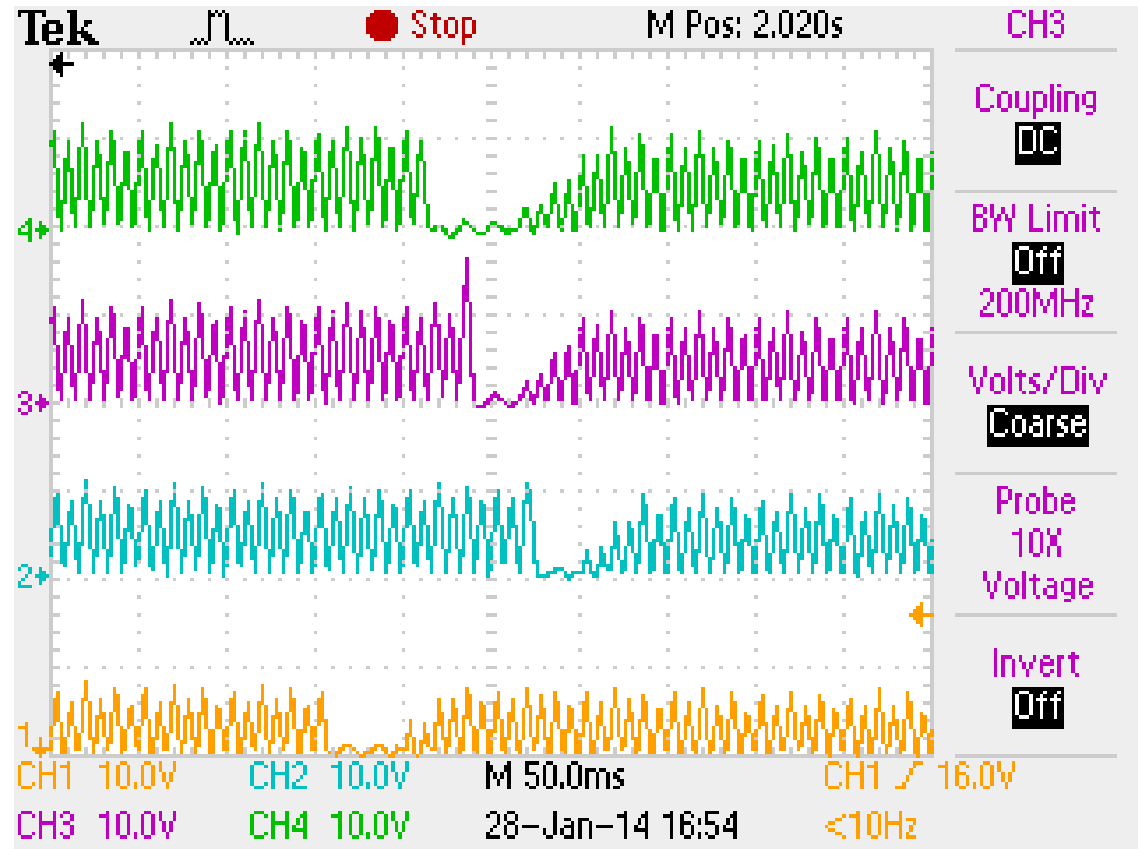

7/22/2018

2018 APC-Wastewater Conference

40



SHEL-B Environmental
Emissions Consulting, Inc.

INSULATORS TRACKING

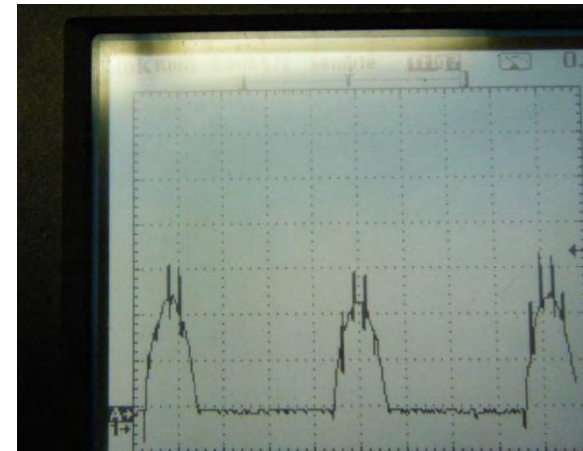
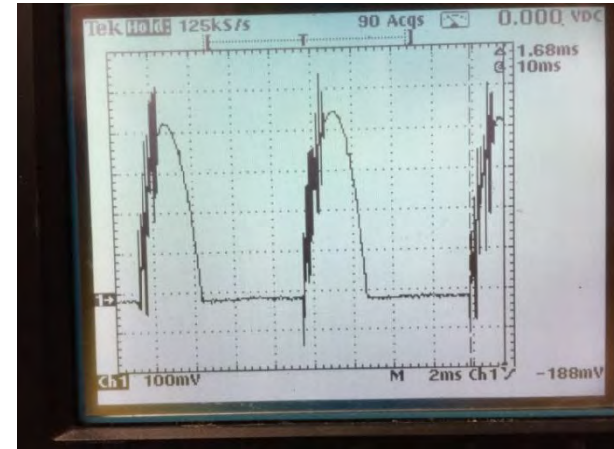

Photos and scope traces courtesy of Southern Company.

7/22/2018

2018 APC-Wastewater Conference

41



SHEL-B Environmental
Emissions Consulting, Inc.

WAVEFORM COMPARISON

Conventional TR Set

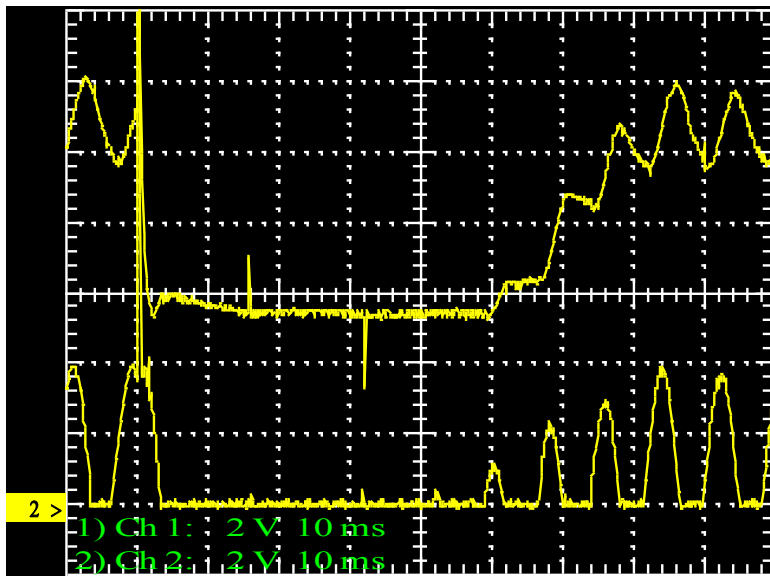

HF TR Set

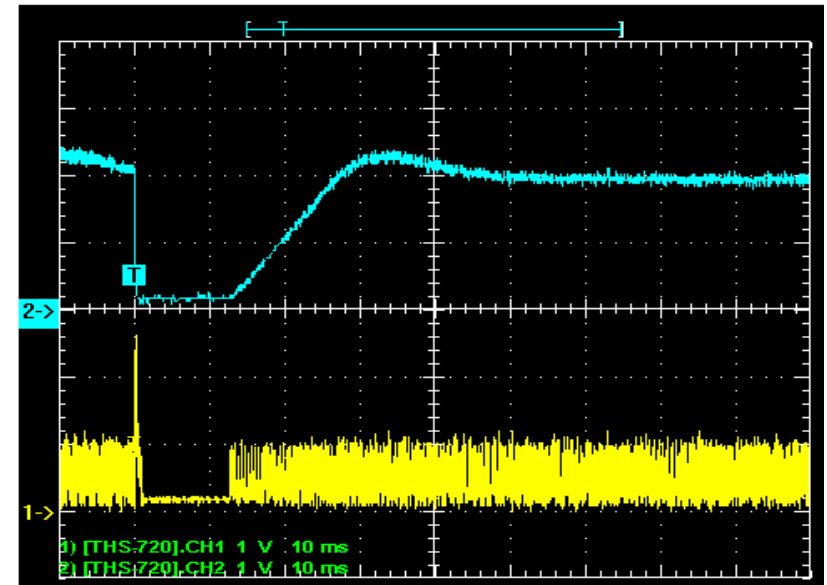

7/22/2018

2018 APC-Wastewater Conference



SMPS WAVEFORMS

SMPS

IE MODE:

“ON” TIME - 1MS

“OFF” TIME - 1 MS

“QUENCH TIME - 4MS

WITH SPARK

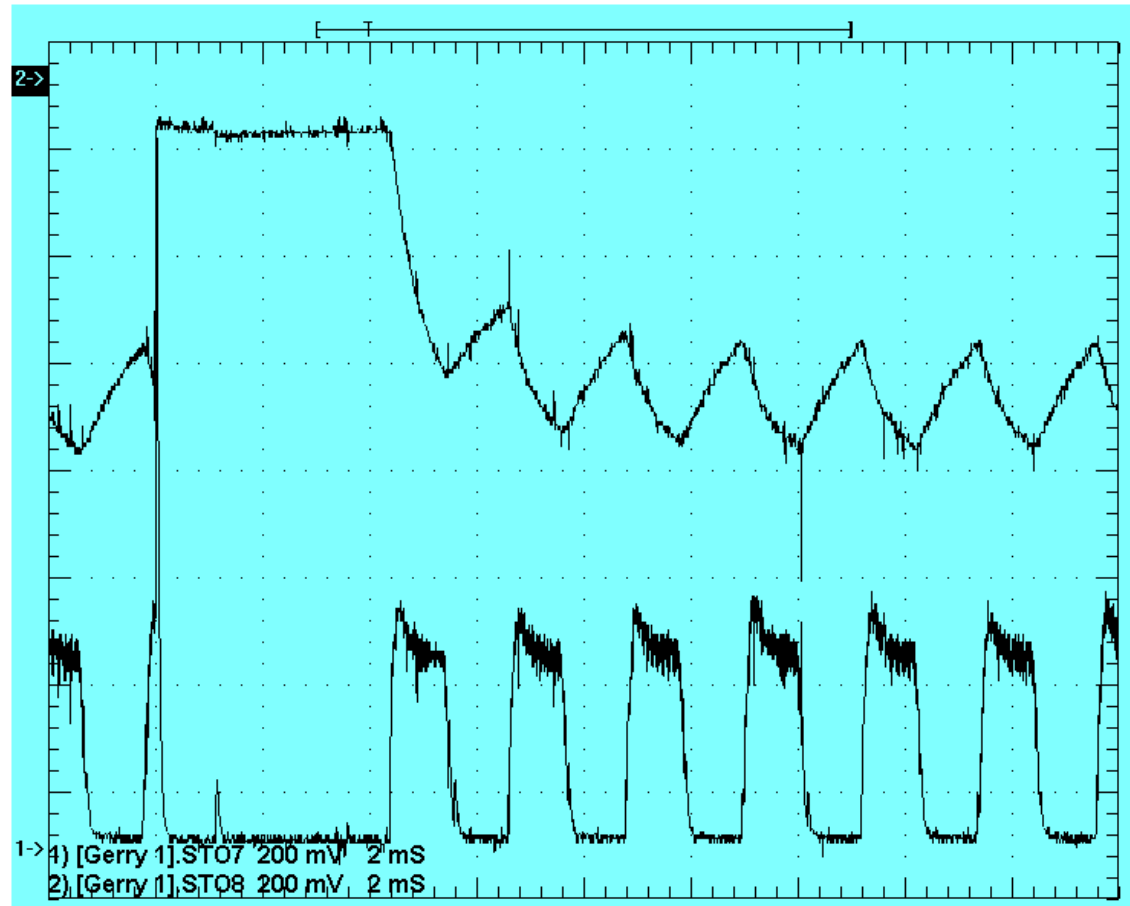

Scope traces courtesy of Southern Company.

7/22/2018

2018 APC-Wastewater Conference

43



SHEL-B Environmental
Emissions Consulting, Inc.

SMPS IGBT GATE PULSE SIGNALS

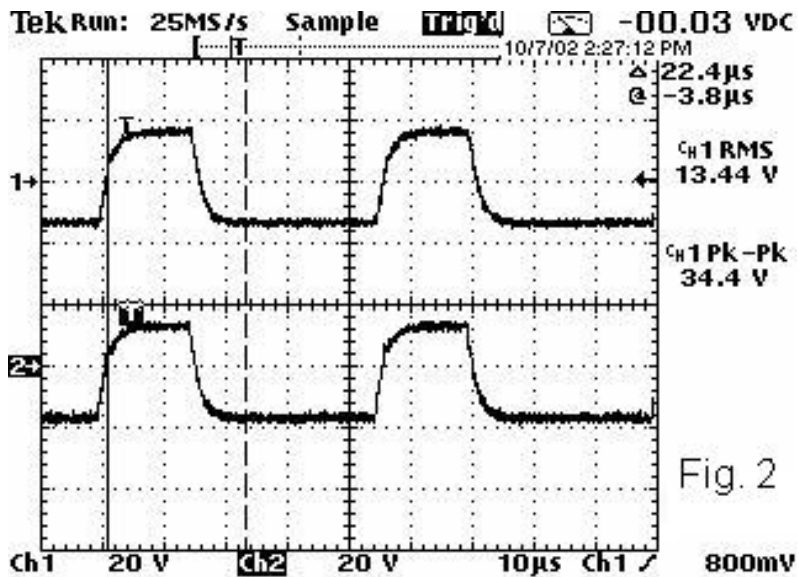

Fig. 2

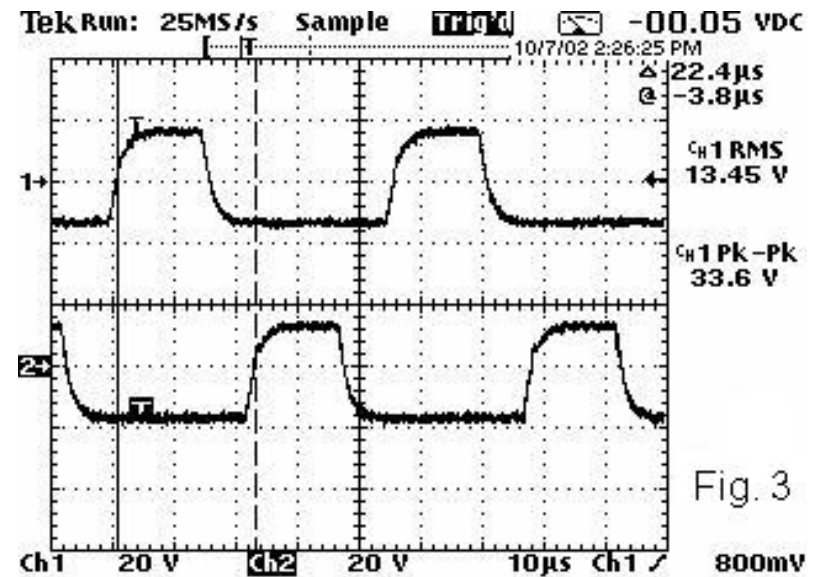

Fig. 3

7/22/2018

2018 APC-Wastewater Conference

